

Series 340, prepASH[®] 2.0 219, 229, 212

Fully automatic drying and ashing systems



Serial number S/N:

Installation date:

350-8193-100a4

Table of contents

Introduction	4
1.1 General notes on the operating instructions	4
1.2 Representation and symbols.....	4
1.3 Safety instructions.....	4
2 Description of the device	5
2.1 Intended use	5
2.2 Structure and function.....	5
2.2.1 Structure of the ashing device.....	5
2.2.2 Functions of the ashing device.....	6
2.3 Technical data	6
2.4 Operating elements and connections.....	7
2.4.1 Front panel controls	7
2.4.2 Operating elements and connections rear panel.....	9
2.5 Furnace chamber.....	10
3 Commissioning	11
3.1 Unpacking.....	11
3.2 Scope of delivery	12
3.3 Selection of a suitable location	12
3.4 Assembly and connection	12
3.5 Adjusting the balance.....	13
3.6 Gas calibration	13
3.7 Mechanical adjustment	13
3.8 Inserting the sample tray.....	14
3.9 Crucible.....	14
4 Software: First steps	15
4.1 Program start.....	15
4.2 Control elements of prepASH.....	15
4.2.1 Buttons	15
4.2.2 Number input	15
4.2.3 Text input.....	16
4.2.4 External keyboard / barcode scanner	16
4.3 prepASH User interface	16
5 Create method / edit	19
5.1 Create new method	19
5.1.1 Parameter selection	20
5.1.2 Calculation of losses and residues.....	21
5.2 Checkweigher	22
5.3 Events on the program end.....	22
5.4 Edit method e/create new method from an existing one	22
6 Program execution	24
6.1 Analysis	24
6.1.1 File name.....	25
6.1.2 Selection of methods.....	25
6.1.3 Tare mode	25
6.1.4 Additional results.....	26
6.1.5 Sample tray	26
6.1.6 Enter the sample density	26
6.2 Sample list.....	27
6.3 Weighing in prepASH and START	28
6.3.1 Tara mode: all/individual	28
6.3.2 Tara mode: all/all	29
6.3.3 Tara mode: single/individual	30
6.4 Weighin in with prepSTATION.....	31
6.5 Reuse weighing	32
6.6 During the measurement	33
6.7 Program end.....	34
6.8 Standby activated/User password	35
7 Calculations	36

8	Main menu	37
8.1	Adjusting the balance.....	37
8.2	Annealing.....	38
8.3	Database/Files.....	38
8.4	Import/Export.....	39
9	Data transfer and prepDATA 2.0	41
9.1	Concept/structure.....	41
9.2	Recommendations.....	41
9.3	LIMS & Data Sharing.....	41
9.3.1	Setting Up Data Sharing	41
10	Utility programs	44
10.1	Audit trail.....	44
10.2	Settings.....	44
10.2.1	User profile	44
10.2.2	About the device	44
10.2.3	Hardware setting.....	45
10.2.4	Analysis settings	46
10.2.5	Database settings.....	46
10.2.6	Device settings	46
10.2.7	Network	47
10.2.8	Date and time	47
10.2.9	Report.....	48
10.2.10	Periphery test	50
10.2.11	Balance adjustment	51
10.3	User administration	51
10.3.1	Create.....	51
10.3.2	Delete.....	51
10.3.3	password	52
11	Service tools	53
11.1	Mechanical settings.....	53
11.2	Gas flow.....	54
11.3	Temperature calibration and adjustment.....	54
11.3.1	Method for temperature calibration/adjustment.....	54
11.3.2	Temperature calibration	55
12	Update prepASH software.....	58
12.1	Preparation	58
12.2	Executing the update	58
13	Maintenance and service	59
13.1	Housing.....	59
13.2	Furnace chamber.....	59
13.3	Chimney.....	59
14	Appendix A: Carbon application.....	61
14.1	Method.....	61
14.2	Measurement.....	62
14.3	Calibration	63
14.3.1	Correction of volatile components	64
14.4	Results.....	64
14.5	Calculations	64
14.5.1	Results.....	64
15	Appendix B: Scrubber application/sulfated ash	65
15.1	Scrubber operation	66
16	Appendix C: UPS/UPS power failure bridging	67
17	Appendix D: Practical recommendations	68
17.1	Correct sample preparation	68
17.2	Optimization of result accuracy and working with very low ash content	68
17.3	Correct crucible handling and weighing	68
17.4	Adaptation of the existing test procedure.....	68
17.5	Possible causes and correction of incorrect results	68

18	Accessories and consumables	70
18.1	Accessories	70
18.2	Consumables	70
19	Technical data	72

Introduction

1.1 General notes on the operating instructions

The prepASH Series 340 drying and ashing device is simple and functional to operate. Please read the operating instructions completely and carefully so that you can make optimum use of the full potential and the many possibilities of the prepASH Series 340 in your daily work.

These operating instructions contain screenshots and icons of the buttons to make it easier for you to find the information you are looking for.

Please refer to chapter 1.2 "Representation and symbols " for the labeling of hazards and instructions.

1.2 Representation and symbols

Important instructions relating to safety are highlighted in the respective job description:

 DANGER
Warning of a possible danger that could lead to death or serious injury.

 CAUTION
Warning of a potentially dangerous situation which could lead to minor personal injury or damage to property.

 NOTE
Tips and important rules for working correctly with the ashing device.

1.3 Safety instructions

- When using the ashing device in environments with increased safety requirements, the relevant regulations must be observed.
- Only install in a sufficiently large, dry and well-ventilated room.
- Only operate the appliance upright on its feet and on a stable, horizontal surface.
- Pollution (contamination) of the atmosphere may only be non-conductive. Short-term conductivity due to condensation may only occur occasionally.
- The appliance must not be operated or stored in corrosive or explosive atmospheres (dust, steam, gas).
- Never operate the appliance with a damaged mains cable.
- Never lay the mains cable over sharp corners and edges or hot surfaces.
- If, for any reason, it can no longer be assumed that the appliance can be operated safely, it must be disconnected from the mains immediately (pull out the mains cable) and secured against unintentional operation.
- Pay attention to hot parts during operation and maintenance work, especially in the area of the furnace chamber (risk of burns).
- When the furnace chamber is opened during operation or after completion of the test, very hot air escapes and the furnace chamber radiates a lot of heat.
- The cover of the ashing appliance must not be used as a shelf or platform. The lid is not mechanically loadable and free heat radiation must be ensured during operation.
- Sample type: do not ash explosive samples.
- The entire electrical system must be checked for proper condition by a specialist before the ashing appliance is used for the first time, after maintenance and repair work on the electrical system and at intervals of at least four years.

2 Description of the device

2.1 Intended use

The ashing appliance may only be used for weighing, drying and ashing solids and liquids. The maximum permissible load of the integrated balance must never be exceeded, otherwise the balance may be damaged.

When using the ashing device in combination with other Precisa devices or devices produced by other manufacturers, it is essential to observe the applicable regulations for the safe use and intended use of the respective additional devices.

! NOTE

Please note that all parts of the prepASH that come into contact in any way with the sample material or its vapors and smoke, as well as with supplied substances such as process gases, are considered wear parts and are therefore excluded from any warranty. These include, for example, the quartz glass pane or the thermal insulation in the combustion chamber, but also the chimney with all its components.

2.2 Structure and function

2.2.1 Structure of the ashing device

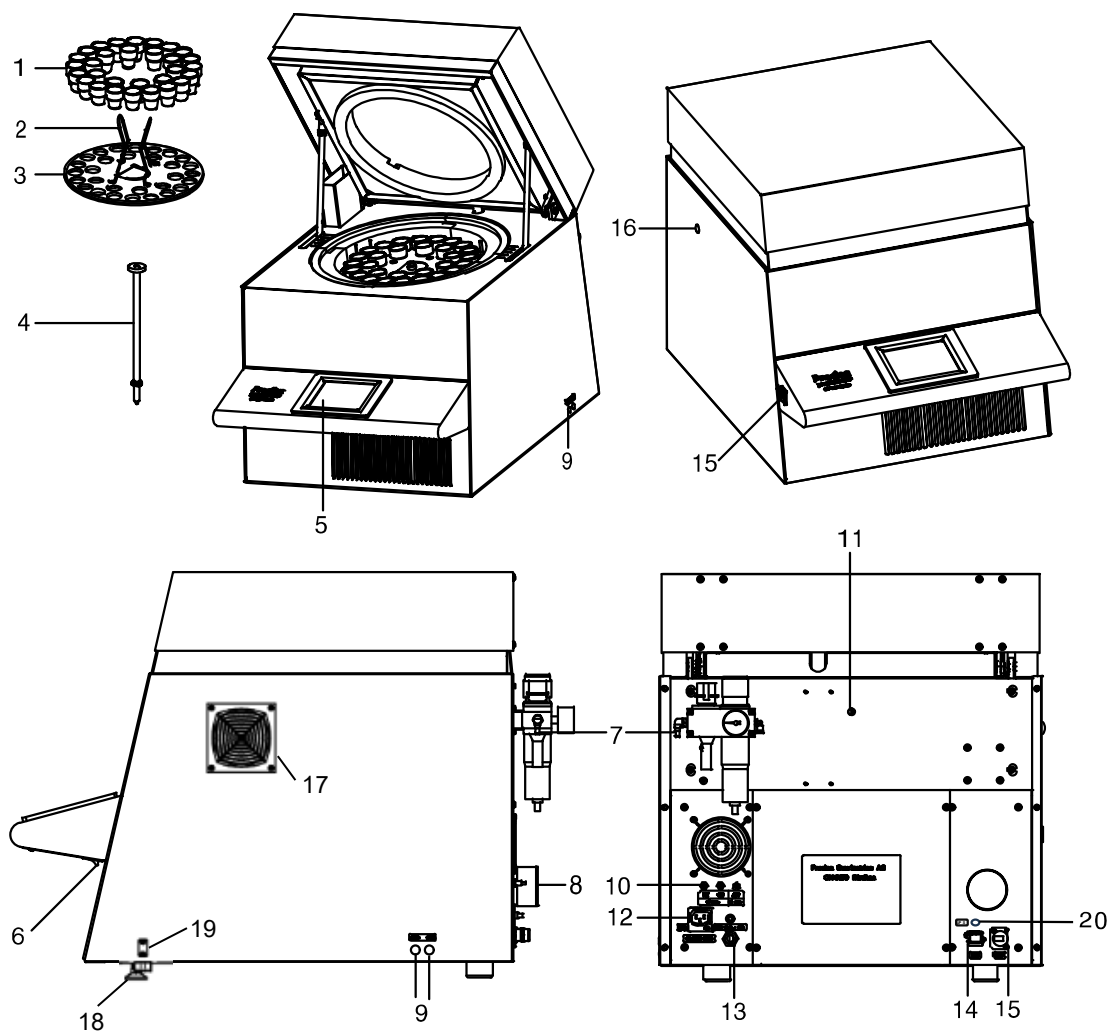

No.	Description	No.	Description
1	Crucible	11	Opening for external thermometer (only for calibration)
2	Plate holder	12	Mains connection for a scrubber or pump
3	Sample tray	13	Mains connection cable with 3-pin CEE plug (male)
4	Weighing pan	14	LAN connection
5	Touch screen	15	USB connection

6	Main switch	16	Mechanical coupling for scrubbers
7	Maintenance unit with compressed air connection	17	Intake opening for cooling (optional)
8	Exhaust gas connection	18	Leveling screws
9	Process gas flow regulation	19	Leveling tool
10	Process gas and compressed air connections	20	UPS connection

2.2.2 Functions of the ashing device

The prepASH Series 340 ashing device is simple and functional to operate. It enables quick and safe drying / ashing of liquid, porous or solid materials. The device works according to the thermogravimetric method.

The most important basic features of the ashing device are:

- Automatic drying, ashing and weighing of up to 29 samples in one run.
- Continuous measurement and logging of all samples over the entire measurement period.
- Automatic compensation of the buoyancy.
- Color touchscreen for easy operation and clear display.
- Temperature range from 50 °C to 1000 °C.
- Access authorization according to CFR 21 part 11.

2.3 Technical data

• Mains connection

- Voltage: 230 VAC (+15/-20 %), for 115V mains connection use two phases
- Power consumption: 5.5kW
- Frequency: 50 to 60 Hz
- Connector: CEE type, 3 pole, 32 A, male, only N (blue), L1 (brown) and PE (yellow green) connected
- Cable length: 2m

• Weighing system

- Weighing range: 120 g
- Resolution: 0.0001 g
- Unit: g

- Number of samples:
 prepASH 212: 0 - 12
 prepASH 219: 0 - 19
 prepASH 229: 0 - 29

• Heating system

- Ceramic infrared radiator
- Temperature range: 50 °C - 1000 °C
- Temperature accuracy: $\leq \pm (1\% + 2\text{ °C})$
- Individually configurable temperature curves
- Auto stop: 0.1-120000 (freely definable) mg/5-200 min

• Results

- Weight loss in %, ‰, g
- Weight loss compared to the previous interval in %, ‰, g
- Residual weight in %, ‰, g
- Residual weight compared to the previous interval in %, ‰, g
- Free calculation
- Free naming

• Monitoring

- Online monitoring on the PC via Ethernet (LAN) using the prepDATA program.

• Gas requirement

- Oxygen: 3 bar ($\pm 10\%$), 0 - 9 l/min, 99.5 % purity
- Nitrogen: 3 bar ($\pm 10\%$), 0 - 9 l/min, 99.5 % purity
- Compressed air: 6 bar $\pm 10\%$, with an air flow rate of 2-3 l/min
 Oil-free and without condensation (ISO 8573-1:2010, at least standard 7.4.4
 (solid particles 5-10 mg/m³, water vapor pressure dew point $< + 3\text{ °C}$, water liquid, oil 5 mg/m³)

Tubing for compressed air with an inner/outer diameter of 6/8 mm or replace with any 1/8" connection, recommended material TPE-A (NOT INCLUDED IN DELIVERY).

Tubing for process gases (outer \varnothing x thickness 4 x 0.75mm), recommended material TPE-A (NOT INCLUDED IN DELIVERY).

- **Furnace atmosphere**
 - Oxygen, nitrogen or compressed air
 - Flow rate measured electronically
- **Interfaces**
 - Two USB interfaces for printer, USB stick, barcode scanner or keyboard.
 - Ethernet (LAN) for online monitoring.
- **Result output**
 - Printout directly on prepASH
 - Creation of a report via prepDATA on the PC.
 - **LIMS**
- **Operation and display**
 - Color touchscreen
 - Menu-driven operation
 - Language-independent operating icons
- **Printout via optional printer**
 - Graphic
 - Method
 - Results and statistics
- **Weight and dimensions**
 - Weight 100 kg
 - Dimensions H(H) x W x D / 620(980) x 590 x 830 mm
 - (H) Height with sample compartment open
- **Required floor space**
 - W x D / 590x830 mm
 - (15cm safety distance required)
- **Permissible ambient conditions**
 - Temperature: 5 °C - 35 °C
 - Relative humidity: 25 % - 85 %, non-condensing
- **Exhaust hose (included in the scope of delivery)**
 - Diameter inside/outside 63/68 mm, length 2 m, flow rate approx. 40m³/h, temperature approx. 50°C. Exhaust gases must be discharged from the working area (hood).

If you have any questions about the technical data or require detailed technical information about your ashing device, please contact your Precisa representative.

2.4 Operating elements and connections

2.4.1 Front panel controls

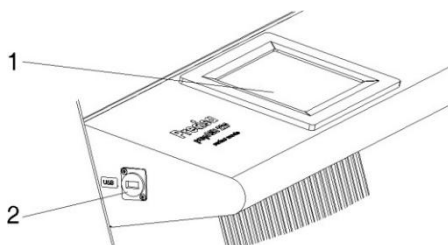

1, 2 The touchscreen (1) allows simple, menu-driven operation. All device settings can be conveniently changed by touching the display. USB port (2) for keyboard, USB stick or barcode scanner.

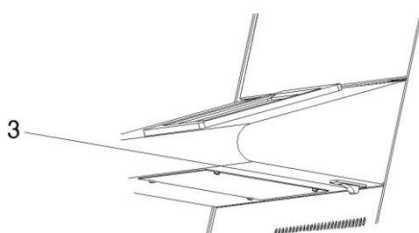

3 The main switch (3) is located on the underside of the console.

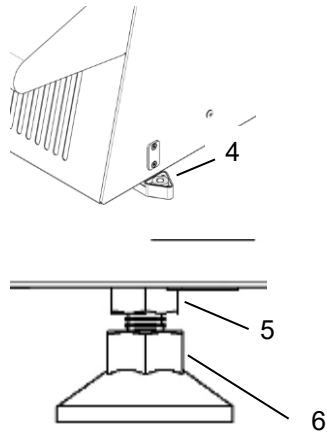

4 Extendable leveling unit (spirit level)

5, 6 Leveling device

- Loosen the lock nuts (5) on both leveling feet leveling feet (open-end wrench SW13)
- Set spirit level (4) horizontally
- Adjust both levelling feet (6) (open-end wrench SW15) until prepASH is perfectly leveled. The leveling foot has a right-hand thread. This means that if you turn it to the right (clockwise) clockwise) the prepASH is lowered.
- Tighten the lock nuts on both leveling feet. leveling feet.
- Return the leveling unit to its original position. starting position.

2.4.2 Operating elements and connections rear panel

⚠ DANGER

The ashing appliance is operated with 230 V alternating current. Have the electrical connection work carried out by a specialist.

The exhaust gas hose must be routed into the exhaust air system in order to safely remove harmful exhaust gases from the furnace chamber.

⚠ CAUTION

The pneumatic system of the prepASH must not be operated with pure oxygen (strong reaction of oxygen and oil).

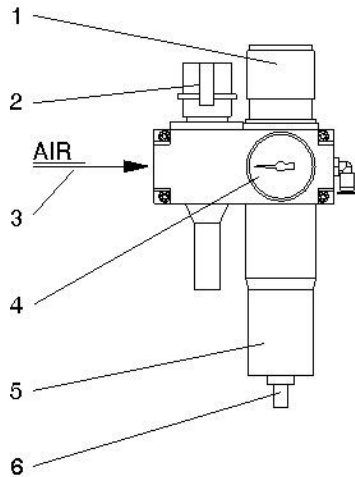

1, 4 Use the regulator (1) and the pressure gauge (4) to set the pressure for the pneumatic supply to the appliance.

2 The pneumatic system of the appliance can be vented or disconnected from the compressed air supply via the switch-on valve (2).

3 The oil-free compressed air must be connected to the maintenance unit (3). We recommend using a compressed air hose with an inner/outer diameter of 6/8 mm that fits the existing connection or replace it with a 1/8" connection.

5, 6 Check the filter (5) regularly for dirt and accumulated condensate. To prevent condensate from entering the appliance, the filter must be emptied manually (6).

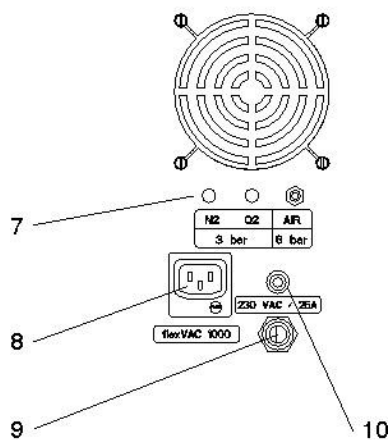

7 The process gases can be fed in with hoses (D x S / 4 x 0.75mm) via the clamp connections (7). The compressed air inlet (AIR) is connected to the maintenance unit at the factory.

CAUTION when handling oxygen and nitrogen.

8 Mains socket for a scrubber (e.g. Büchi B-415) or pump.

9, 10 Mains connection cable 2 m with 3-pin CEE type plug, male (only N, L1 and PE connected).

The circuit breaker (10) disconnects the appliance from the power supply in the event of an overload. After investigating and rectifying the fault, the circuit breaker can be pushed in again.

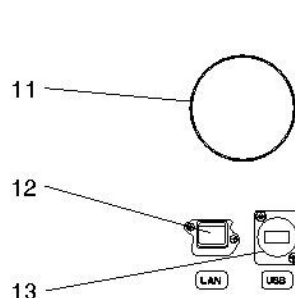

11 The hose supplied is fitted to the flue gas connection (11) using the clamp and the other end is fed into the exhaust air system.

12 LAN connection (12)

13 USB connection (13)

2.5 Furnace chamber

⚠ CAUTION

The internal parts in the furnace chamber and the tray cover become hot, so take the necessary care when opening and loading the furnace chamber.

Always use the holders supplied to remove the Sample tray from the device. When removing individual crucibles, always use the crucible tongs supplied (this also prevents incorrect measurements).

ⓘ NOTE

Handle the sample tray, crucible and weighing pan with care. These parts are made of ceramic and are sensitive to impact.

Pay attention to the sensitive insulation when charging the appliance.

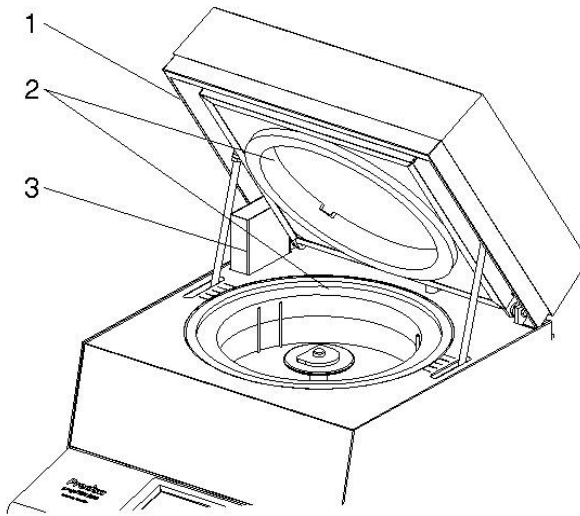

1 The circlip (1) prevents jamming when closing the lid.

2 The entire furnace chamber is lined with insulation inserts (2).

3 The suction device (3) can be seen at the rear left.

CAUTION: Watch out for hot spots when handling the appliance.

The following parts are visible when the sample tray is removed:

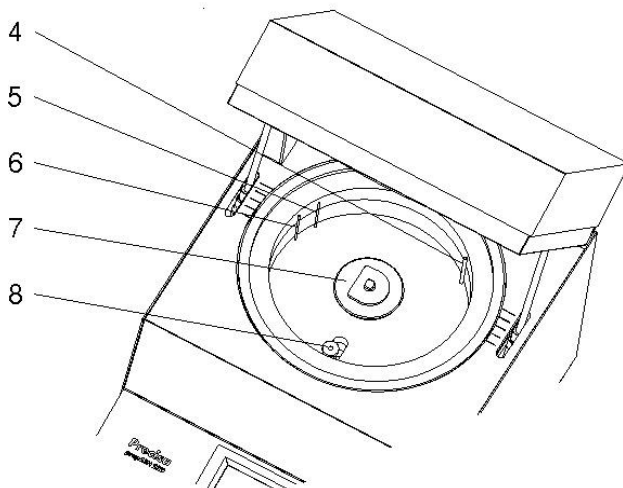

4 The process gases (N₂, O₂ or compressed air) are fed into the furnace chamber with the lance (4).

5 The temperature sensor (5) measures the furnace chamber temperature.

6 The additional temperature sensor (6) protects against overheating in the event of a defect or incorrect temperature calibration.

7 The rotary axis (7) holds the sample tray.

8 The weighing pan (8) is inserted in a protective tube.

3 Commissioning

3.1 Unpacking

To avoid damage, the following points must be observed when unpacking the ashing device:

- Check the ashing device for visible external damage immediately after unpacking. If you notice any damage during transportation, please inform your Precisa service representative immediately.

! NOTE

The insulation material is a natural mineral building material. Temperatures of up to 1000°C are reached in the furnace chamber during our final inspection. It therefore cannot be ruled out that stress cracks may occur in the insulation material as a result. Do not worry, these effects do not affect the measurement results, the safety of the instrument, the working environment or the employees.

- Read through these operating instructions before working with the ashing device and be sure to observe the safety instructions (see chapter 1.3 "Safety instructions").

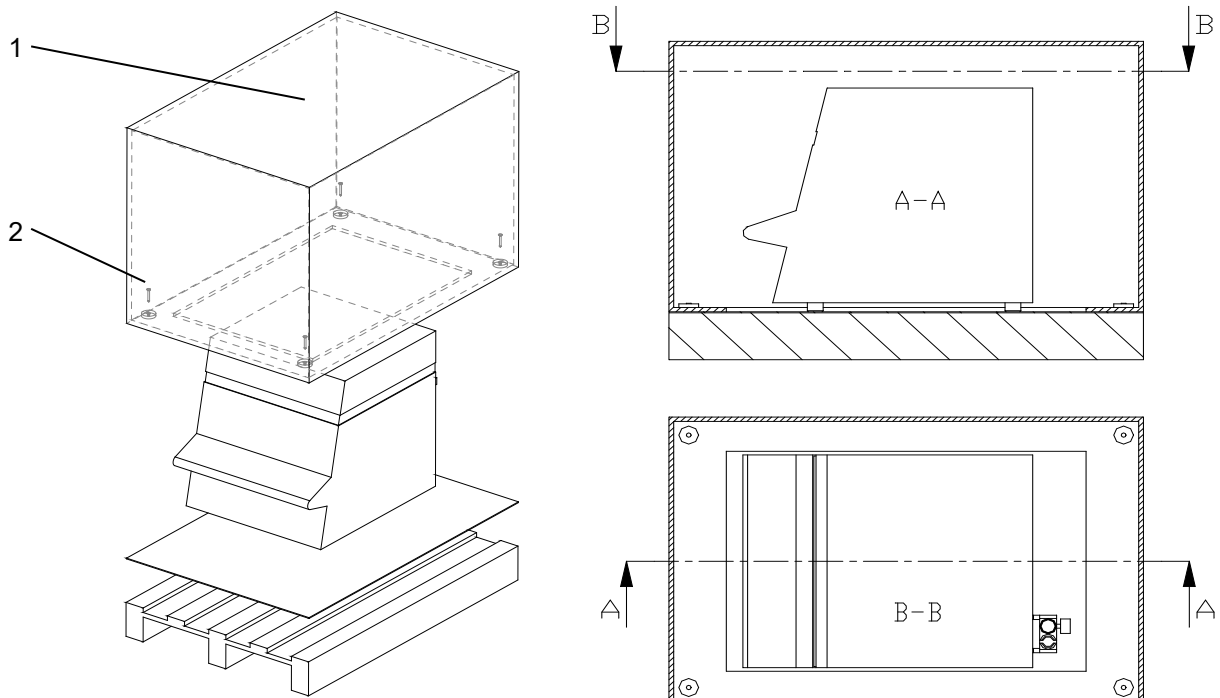

Unpacking the prepASH

1. Open the top of the box (1)
2. Remove all upholsteries and accessories
3. Loosen four screws (2) at the bottom of the cardboard box
4. Lift the cardboard box upwards

! NOTE

Keep the packaging. If the appliance is sent to the factory for repair by a transport company after prolonged use, only send it in its original packaging. Poorly packaged appliances can be severely damaged during transportation.

3.2 Scope of delivery

Check that the delivery is complete immediately after unpacking all parts:

Naming	available yes / no
Ashing device	
Sample tray	
15 crucibles for prepASH 212	
25 crucibles for prepASH 219	
35 crucibles for prepASH 229	
Weighing pan	
2 sample tray holders	
Crucible tongs	
Mains plug	
Exhaust hose	
Clamp for exhaust hose	

3.3 Selection of a suitable location

To ensure that your ashing device functions properly and can be operated safely, the location must be selected so that the permissible ambient conditions (see chapter 2.3 "Technical data " on page 6) are complied with and the following requirements are also met:

- The installation room must be of sufficient size (room volume at least 10 m³) and well ventilated.
- Observe the following safety distances to neighboring appliances, equipment and walls: minimum lateral distances of 15 cm, minimum distance to the ceiling of 1.5 m.
- Place the ashing appliance on a vibration-free, stable and horizontal surface.
- Protect the ashing appliance against falling.
- Do not expose the ashing appliance to direct sunlight.
- Ensure that air conditioning and ventilation systems are switched off during weighing and do not affect the weighing process

NOTE

The ashing device is a precision instrument. Protect the device from strong vibrations. Vibrations from neighboring devices can affect the measurements of the ashing device.

3.4 Assembly and connection

NOTE

All parts must be able to be plugged together without force. Do not use force. Precisa customer service will be happy to help you with any problems.

The ashing device is supplied in a partially disassembled state. Carry out the individual work steps in the sequence shown below:

1. Have the mains plug assembled by a specialist:

L	→	230 VAC phase
E	→	Protective earth
N	→	Neutral
2. If necessary, remove the protective caps from the connections (process gases) on the rear panel of the appliance.
3. Connect the compressed air, the process gases, the mains cable and the exhaust hose to the connections provided (see chapter 2.4.2 Operating elements and connections rear panel).
4. Regulate the pressure of the compressed air supply using the attached maintenance unit (see chapter 2.4.2 Operating elements and connections rear panel
5. To connect a scrubber or pump, please refer to the chapter 0 .
6. Align the prepASH using the adjustable feet and the built-in leveling unit.

! DANGER

The ashing appliance is operated with 230 V alternating current. Have the electrical connection work carried out by a specialist.

Existing electrical installations must be checked by a specialist to ensure that they are in proper condition and that the fuses and cable cross-sections are sufficiently dimensioned in accordance with the connection data on the type-plate of the ashing device.

The exhaust gas hose must be routed into the exhaust air system in order to safely remove harmful exhaust gases from the furnace chamber.

For further assembly, it is necessary to start the ashing device and open the furnace chamber.

7. Press the main switch on the front of the appliance (see chapter 2.4.1 "Front panel controls" on page 7)
8. The software starts automatically.
9. When you log in for the first time, you are automatically logged in as an administrator without a password. After defining the users, select their access and enter their password. (-> 10.2.1 User profile).
10. Open the function bar. (click in the green area)

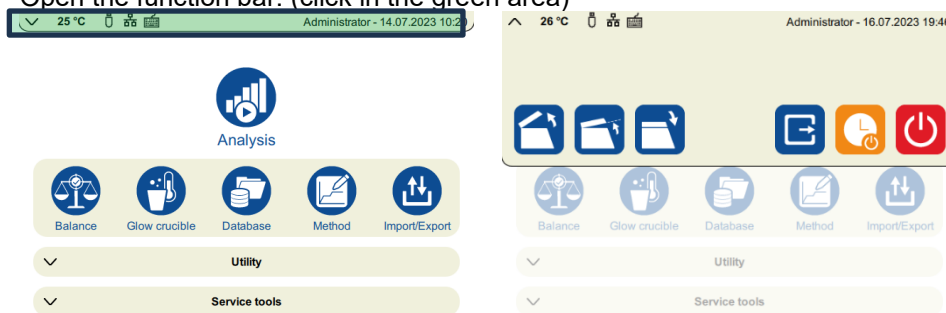

11.  Open the prepASH lid.
You can now remove the protective cover over the ceramic tube and insert the weighing pan.
12. Remove the protective plug from the balance and insert the weighing pan support. The information field then appears to check that it has been inserted correctly. After pressing OK, the balance is restarted.
13. The balance must be adjusted.

3.5 Adjusting the balance

Before commissioning, the balance must be adjusted to the site-specific acceleration due to gravity. It is recommended to adjust the balance periodically. The procedure is described in chapter 8.1 "balance" on page 37 .

3.6 Gas calibration

The gas flow must be finely adjusted after setting the pressure. The procedure is described in chapter 11.2 Gas flow .

3.7 Mechanical adjustment

The mechanical adjustment is carried out at the factory. The lifting and rotating movements of the sample tray are checked by the technician during installation.

3.8 Inserting the sample tray

Carefully place the sample tray on the axis of rotation.

! NOTE

The small hole in the sample tray must be located in the area to the left of the weighing pan (see illustration on the right).

The ashing device is now ready for operation.

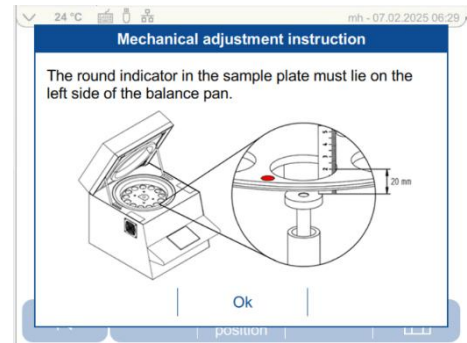

3.9 Crucible

! NOTE

Anneal the crucible before first use.

4 Software: First steps

4.1 Program start

The terminal is also switched on by pressing the power switch on the ashing device.

After the start process, the login page appears. Select the user and enter your password. (Create user: 10.2.1 User profile)

The factory setting on delivery: the login page is not displayed and you are automatically logged in as administrator (without password).

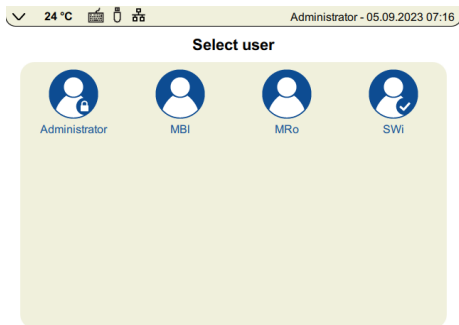

The following window appears depending on the selected login level.

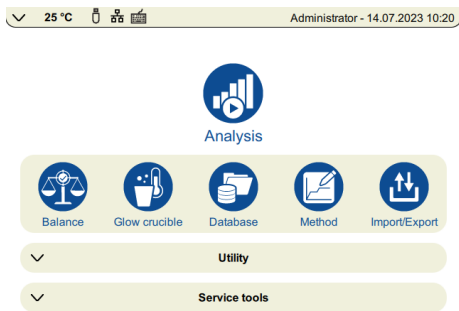

Administrator



Restricted user

4.2 Control elements of prepASH

4.2.1 Buttons

The command is executed by pressing a button.

		Inactive icons change their color to grey:
		Click on the <i>arrow buttons</i> to switch between the main menu pages of the prepASH user interface. Unless otherwise described the following instructions for the program switch one page to the right at a time.
		Scrolling within a menu.
		Many settings are automatically applied when you leave the page. Where saving is necessary, the save button is available

4.2.2 Number input

It is necessary to enter numerical values at various points in the program.

After tapping the respective field or the number to be changed, the window for entering numbers appears.

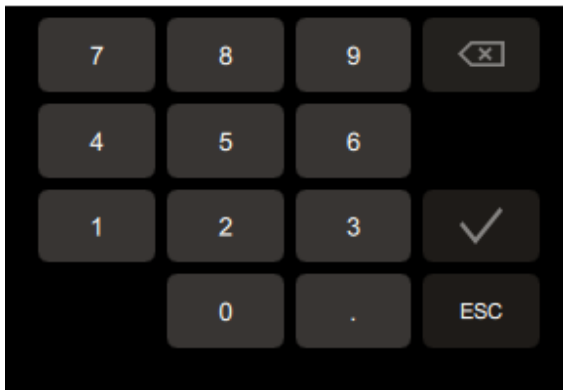

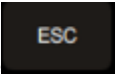
Enter the desired number and confirm with  or cancel the process using the  button.

4.2.3 Text input

In places where names are entered, the window for entering text in your selected keyboard language appears after tapping (see 10.2.6 Device settings).

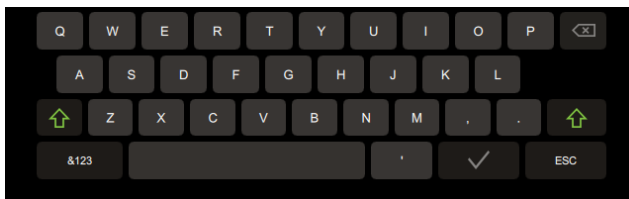

Enter the desired text and confirm with



or cancel the process by

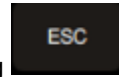

pressing



Press the  /"Shift" button to switch between upper and lower case.

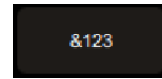

changes to special characters



switches between the two special keyboards.

4.2.4 External keyboard / barcode scanner

Numbers and text can also be entered using an external keyboard or barcode scanner. To do this, connect the keyboard or barcode scanner to the prepASH USB port. The device is automatically recognized. If necessary, adjust the keyboard language in the device settings (10.2.6 Device settings).

4.3 prepASH User interface

The user interface options depend on the authorizations.

The user interface can be used to carry out the analysis for drying and ashing and crucible annealing programs, calibrate the balance, view and export data. Methods, utilities and service tools are dependent on access authorization.

Menu items without authorization are highlighted in grey, icons are not available.

The screen is divided into 5 areas.





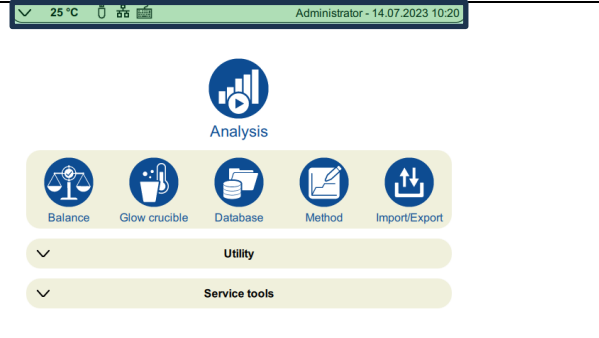
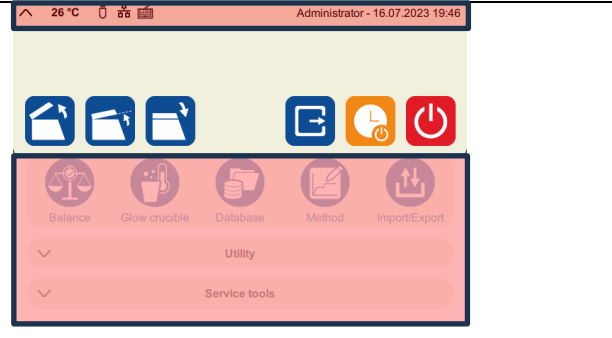
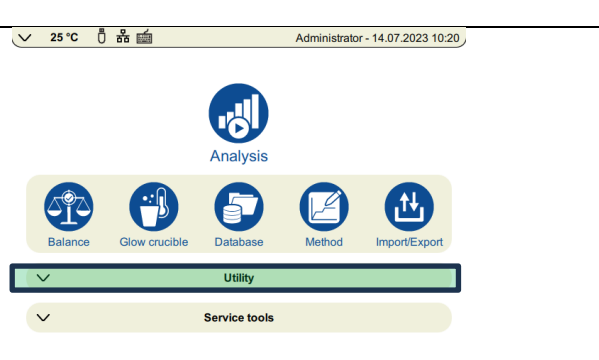
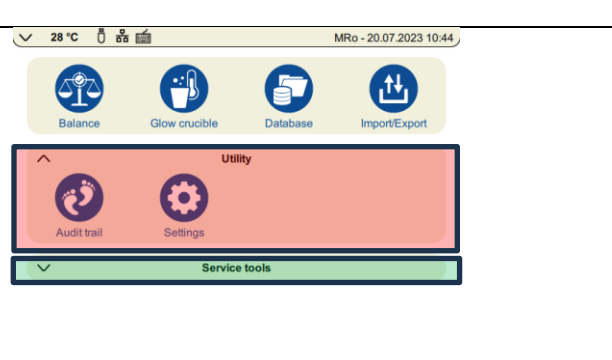

- Function bar
- Analysis
- Menu
- Utility program
- Service tools

Important functions can be accessed from the various windows by expanding the function bar.

The main menu is always displayed, analysis, utility program and service tool are displayed alternatively, so opening one area automatically hides the others.

	
<p>Open the function bar: Click in the green area</p>	<p>Close the function bar: Click in one of the red areas</p>
	
<p>Open the utility program by clicking in the green area</p>	<p>Close the service program by clicking in the red area or by opening the service tools. Close the utility program and service tool to make the analysis accessible.</p>

Existing functions in the function bar:

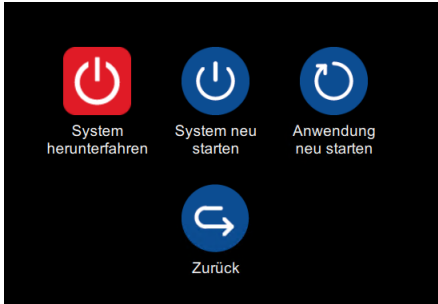
	<p>Open the lid</p>
	<p>Opening/closing the cover to the center position</p>
	<p>Close lid</p>
	<p>Log out user</p>
	<p>Set prepASH to stand-by mode This locks the screen (also possible during analysis) and must be unlocked with a password. (-> 6.8 Standby activated/User password</p>
	<p>Shut down terminal: choose between the following options.</p> 

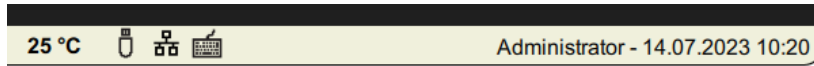

The display bar at the top of the user interface shows the current temperature and the connections such as keyboard, USB stick and LAN.

The user, date and time are displayed on the right.

The display power always remains visible in the main menu pages and during an analysis.

5 Create method / edit

Methods can only be created and edited by authorized persons.

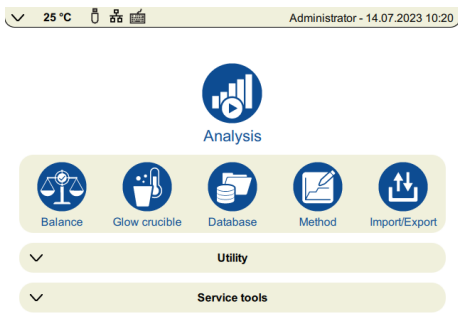

Click on the button for methods.

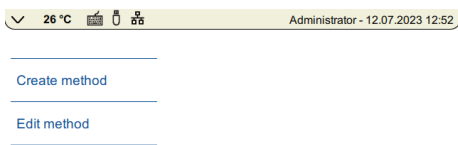

Select whether you want to create the method from scratch or derive it from an existing method.



5.1 Create new method

Select Create method

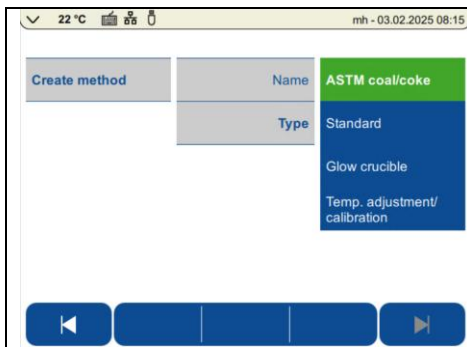

Choose whether you

- a method for the proximate analysis of coal (incl. volatiles, only with appropriate device configuration)
- a standard method
- a method for annealing the crucibles (no results, no autostops)
- or want to create a method for temperature adjustment/calibration.

Enter the desired method name.

Use the arrow to the right to switch to the next window.

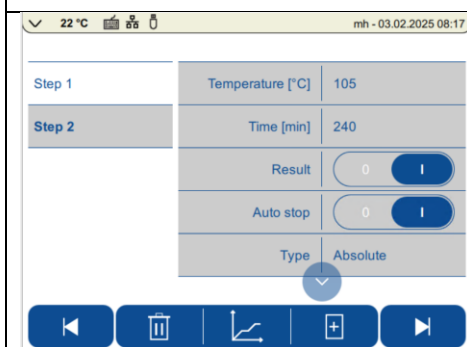

A method can contain up to 15 program levels, within each of which individual parameters can be defined. The maximum total duration of the analysis is 50 hours.

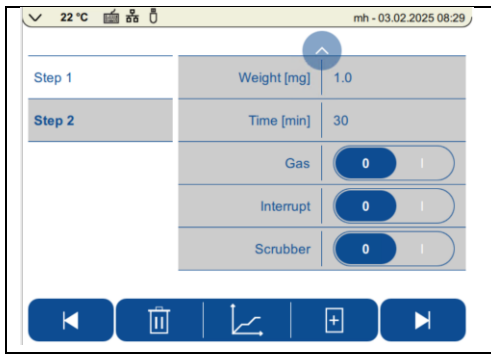

Enter the parameters for each program level separately.
 Within a program level, navigate up/down using the arrows to enter all parameters



Adding or deleting program levels

Program levels that have already been defined can be selected directly by clicking on the tab on the left. During the program sequence, prepASH processes all stages in which parameter settings have been made. The appliance then automatically switches to the cooling stage.



Here you can switch to the graphical display. This helps you to get a quick overview of the method.

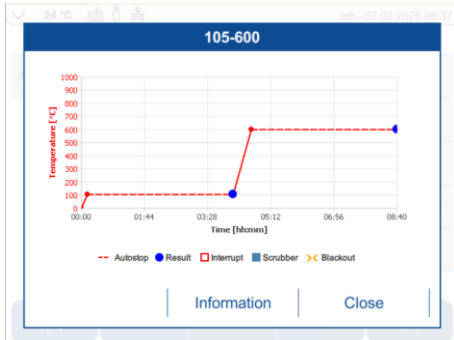

5.1.1 Parameter selection

Each program step contains at least the time and temperature settings.

You can activate further entries by setting the corresponding switch to on.

Tapping on the corresponding field opens the input window and the desired value can be entered using the keyboard.

Use "Graph" and "Steps" to switch back and forth between the tabular input page and the graphical overview.

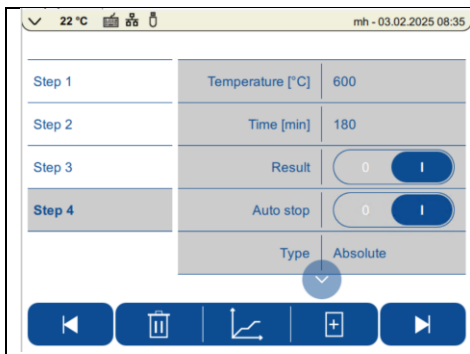

Naming the parameters

Temperature [°C]	Temperature at the end of the program step. This is achieved by a linear temperature gradient, starting from the end temperature of the previous program step, over the duration of the program step. Maximum temperature: 1000 °C
-------------------	---

Time [min]	Duration of the program stage. The maximum total duration of the analysis is 50 hours. This can be distributed over the individual method steps as required.
Gas	Move the switch to on if a process gas is required for this step (only possible if the gas unit is available) Three gas connections (air, nitrogen, oxygen) allow the atmosphere to be determined during the program stage. Possible flow rates are 0, 3, 6 or 9 l/min.
Result	Activate "Result" to mark the program steps at the end of which you would like to define a result. A result can be determined at the end of each method step (the initial weight is always available and does not need to be marked additionally). The mass is usually determined after drying and ashing have been completed.
Interrupt	If you activate the interruption, the program is interrupted at the end of the step and the lid is opened as soon as the temperature falls below the selected temperature. The lid opening temperature can be selected for each method step. The sample tray can be removed from the prepASH, for example to add ashing additives. After clicking on "Next", the lid closes automatically and the measurement continues.
Individual cover opening temperature	An individual lid opening temperature can be selected for each interruption. If none is defined, the lid opening temperature defined at the end of the program is used.
Manual cover opening	This option is only available for methods with the type: ASTM coal/coke and only for the drying 2 step. If you select this option, you must open the lid manually.
Autostop (AS)	If a program step is to continue until the weight is constant, activate the Autostop. Define the weight constancy: absolute as mass change/time (0.1 - 120,000 mg / 2-200 min) or relative as % of weight per time (0.1-100 %/5-200 min). When all samples have reached the autostop criterion, the program switches to the next method step. The weight of each individual sample is saved at the time the auto-stop criterion is reached. You will find the auto-stop time for each sample in the log. If the minus sign is selected, only the weight loss is used for the AS calculation. Without the minus sign, weight loss and weight gain are taken into account.
Scrubber	When activated, the externally connected scrubber or pump is switched on in this program stage. This is. Important, for example, when determining sulfated ash for all steps in which the acid is reduced.

5.1.2 Calculation of losses and residues

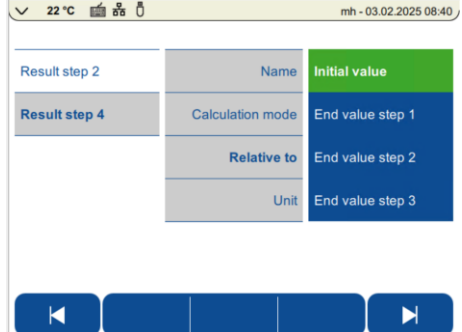
	<p>The type of calculation must be determined individually for each result in the selection menu.</p> <p>Each result can be calculated as a remainder or loss in percent, per thousand or as an absolute amount in grams.</p> <p>The results can be related to the initial weight or to the end of each previous program step of each previous method step (W_n).</p> <p>In the case of losses, W_n is used both as a subtrahend in the denominator and as a numerator:</p> $Verlust = \frac{W_n - \text{aktueller Wert}}{W_n}$
---	---

<div style="border: 1px solid black; padding: 5px;"> <p style="text-align: center; background-color: #0056b3; color: white; margin: 0;">Calculation</p> <div style="border: 1px solid green; padding: 2px; margin: 5px 0;">('C'-W2')+I' ✓</div> <p style="font-size: 8px; margin: 0;">C Current value I Initial value Wn End value step n</p> <div style="background-color: #333; color: #ccc; padding: 5px; margin: 5px 0;"> <table style="width: 100%; border-collapse: collapse;"> <tr> <td style="padding: 2px 5px;">C</td><td style="padding: 2px 5px;">I</td><td style="padding: 2px 5px;">W1</td><td style="padding: 2px 5px;">W2</td><td style="padding: 2px 5px;">(</td><td style="padding: 2px 5px;">-</td><td style="padding: 2px 5px;">7</td><td style="padding: 2px 5px;">8</td><td style="padding: 2px 5px;">9</td><td style="padding: 2px 5px;">←</td> </tr> <tr> <td style="padding: 2px 5px;">W3</td><td style="padding: 2px 5px;"></td><td style="padding: 2px 5px;"></td><td style="padding: 2px 5px;"></td><td style="padding: 2px 5px;">)</td><td style="padding: 2px 5px;">*</td><td style="padding: 2px 5px;">4</td><td style="padding: 2px 5px;">5</td><td style="padding: 2px 5px;">6</td><td style="padding: 2px 5px;"></td> </tr> <tr> <td style="padding: 2px 5px;"></td><td style="padding: 2px 5px;"></td><td style="padding: 2px 5px;"></td><td style="padding: 2px 5px;"></td><td style="padding: 2px 5px;">-</td><td style="padding: 2px 5px;"></td><td style="padding: 2px 5px;">1</td><td style="padding: 2px 5px;">2</td><td style="padding: 2px 5px;">3</td><td style="padding: 2px 5px;">✓</td> </tr> <tr> <td style="padding: 2px 5px;"></td><td style="padding: 2px 5px;"></td><td style="padding: 2px 5px;"></td><td style="padding: 2px 5px;"></td><td style="padding: 2px 5px;">+</td><td style="padding: 2px 5px;"></td><td style="padding: 2px 5px;">0</td><td style="padding: 2px 5px;">.</td><td style="padding: 2px 5px;">ESC</td><td style="padding: 2px 5px;"></td> </tr> </table> </div> </div>	C	I	W1	W2	(-	7	8	9	←	W3)	*	4	5	6						-		1	2	3	✓					+		0	.	ESC		<p>Free calculation: A formula can also be entered in the method as an analysis result. The following values are available as variables:</p> <p>I:= initial weight (initial) C:= End value of the current step (current) W1,...Wn:= Final values of the nth program step, all program steps are counted, not just those for which a result was selected.</p> <p>Variables are bracketed with '.</p>
C	I	W1	W2	(-	7	8	9	←																																
W3)	*	4	5	6																																	
				-		1	2	3	✓																																
				+		0	.	ESC																																	
<table border="1" style="width: 100%; border-collapse: collapse;"> <tr> <td style="width: 20%;">Result step 2</td> <td style="width: 30%;">Name</td> <td>LOI</td> </tr> <tr> <td>Result step 4</td> <td>Calculation mode</td> <td>Frei</td> </tr> <tr> <td></td> <td>Calculation</td> <td>(W2-'C')+I'</td> </tr> <tr> <td></td> <td>Unit</td> <td>%</td> </tr> </table>	Result step 2	Name	LOI	Result step 4	Calculation mode	Frei		Calculation	(W2-'C')+I'		Unit	%																													
Result step 2	Name	LOI																																							
Result step 4	Calculation mode	Frei																																							
	Calculation	(W2-'C')+I'																																							
	Unit	%																																							

5.2 Checkweigher

Weight:
Enter the upper and lower limit values in g.

percent:
Enter the nominal value in g and the upper and lower limits in % of the nominal value.

5.3 Events on the program end

	<p>Fan running at: At temperatures above this value, the extraction system runs and the lid is cooled. The fan must run before the decomposition of the organic compounds begins (temp. <= 200 °C).</p> <p>Cover open at: Temperature below which the lid is automatically opened at the end of the program (in the middle position). Opening is only permitted for temperatures below 600 °C.</p> <p>Cover close at: Temperature below which the lid is automatically closed again.</p> <p>Cooling time: only if rapid cooling (ECD) is connected. Duration of active cooling after the end of the analysis</p> <p>Acoustic signal: When the marker is set, prepASH uses a loud acoustic signal to indicate the end of the analysis</p>
<div style="border: 1px solid black; padding: 5px; text-align: center;"> </div>	<p>Save the method.</p>

5.4 Edit method e/create new method from an existing one

Select the Edit method button to edit an existing method and save it under a new name. This is often quicker than creating a new method.

The methods are stored in the "Standard", "ASTM", "Ausglühen" and "Temp." groups.

Standard

ASTM

Ausglühen

Temp.

Click at the top left to switch between the groups (the annealing methods are only available for annealing, Temp. contains the programs for temperature calibration)

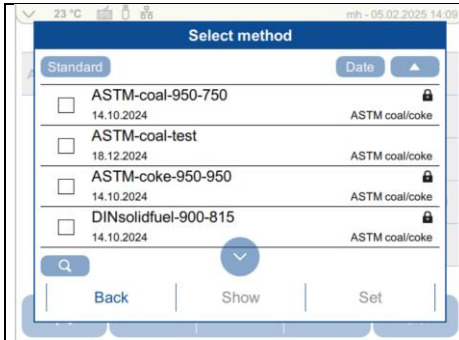

Select the desired method from the drop-down menu.
Sort by alphabet, date, ascending or descending order or use the search function:



Give the new method a name (the type of a method cannot be changed when editing).

The window with the graphical overview of the method opens. Click on "Steps" to change the parameters in the desired program steps.
The procedure is identical to that for creating a new method.
Save the changes.

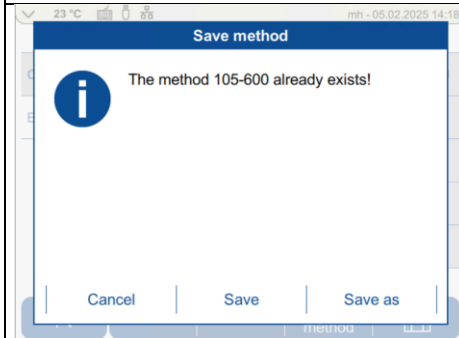

If you have not selected a new method name at the beginning, you will be warned.



Factory methods cannot be overwritten, they are marked with a lock

6 Program execution



Press  to go directly from the main menu to program execution.

If the icon for the analysis is not visible, close the utility program or the service tools.

0 About the device	prepDATA import	Reuse weighing
	Please check prepDATA-manual	Has to be enabled in "10.2.4Analysis settings"
Method has to be entered in prepASH, Users have to be defined in prepASH		
Sample list either direct in prepASH or in prepDATA	Sample list in prepDATA (or in prepASH)	Sample list including tara and weighing in are reused
weighing in directly in prepASH	Weighing in in prepSTATION	Weighing in data are reused
Chose method in prepASH	Chose method in prepDATA	Chose method in prepASH
Chose sample plate in prepASH	Chose sample plate in prepDATA	Chose sample plate in prepASH

6.1 Analysis

Analysis (direct weighin in in prepASH)



Analysis

prepDATA import

Reuse weighing



Follow the on-screen instructions, select the required options and fill in the required fields.

Use the arrow to the right to go to the next page. If information is still missing, the button is inactive, and the arrow is grayed out.

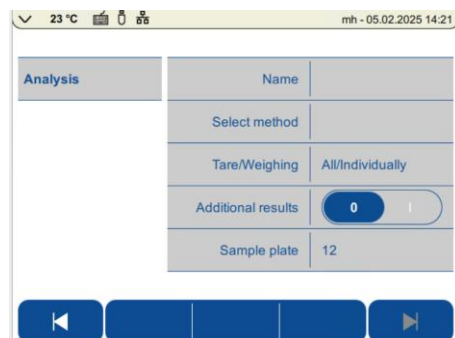

6.1.1 File name

Enter the file name for the data of this analysis.

It is not possible to overwrite data files. If you select an existing file name, you will be notified of this via an information box.

6.1.2 Selection of methods

The methods are stored in the "Standard", "ASTM", "Annealing" and "Temp." groups



Click at the top left to switch between the groups (the annealing methods are only available for annealing, Temp. contains the programs for temperature calibration)

Select the desired method from the drop-down menu and accept it by clicking "Set". The methods can be displayed by date or name, in ascending or descending order.

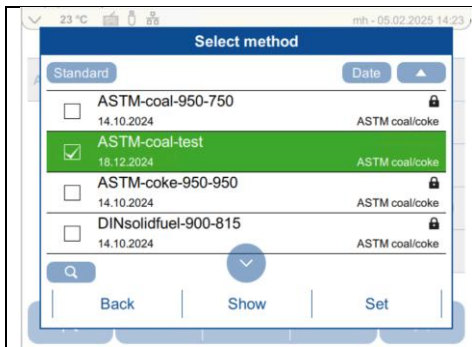

Click on "Show" to open the method for checking. However, the method cannot be edited.

Use "Graphic" and "Information" to switch between the two views.

Close the method view with "Close" and confirm the method selection with "Select".

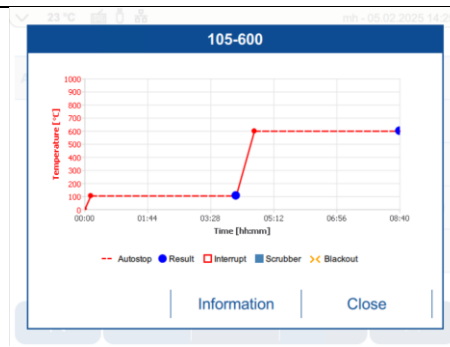
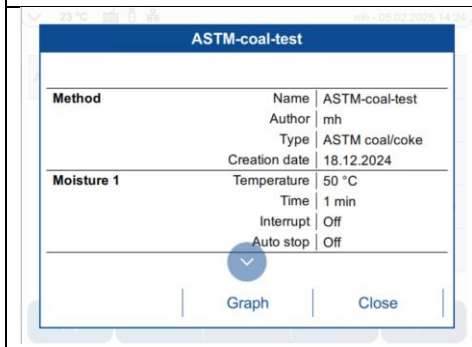

Information

Graphic

6.1.3 Tare mode

Select the tare mode from the pull-down menu.

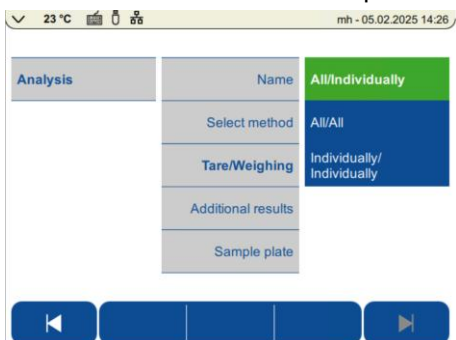

<p>Tare all / Weigh-in individual</p>	<p>Step 1: The lid is automatically closed to determine the tare weight of the crucible. All empty pans are automatically weighed and their tare weights stored. Step 2: Open the lid using the touchscreen, determine the weight for each sample individually and save this value.</p>
---------------------------------------	---

Tare all / Weigh-in all	<p>Step 1: All empty pans are weighed and their tare weights recorded. The lid closes automatically.</p> <p>Step 2: Open the lid and pour all samples into the crucibles (e.g. pipette or measuring spoon) without weighing. If you select the weighing aid, the items are presented for filling.</p> <p>After filling, the lid is closed and weighing takes place automatically.</p> <p>Checkweigher: If a sample weight is not within the tolerance range, it is marked and you can choose whether you want to change the sample weight or carry out the analysis with existing ones. Out-of-tolerance weights are noted in the report.</p>
Tare individual / Weigh-in individual	<p>Weigh the empty pan and record its own weight.</p> <p>Then place the sample in the crucible and determine its weight.</p> <p>Repeat this procedure for each sample.</p> <p>The lid remains open.</p>

6.1.4 Additional results

Select additional results if you require further calculations in addition to the results defined in the method. These can then be defined once the measurement has been completed.

ATTENTION: The analysis is not automatically completed here. This is particularly important when working with the standby option (6.7Program end6.76.8 Standby activated/User password

6.1.5 Sample tray

If you are using different sample trays (12-19/29), make sure that the correct sample tray is in prepASH and that this is also selected in the software. The sample tray can be changed here or in the settings (10.2.3Hardware setting).

6.1.6 Enter the sample density

The sample density can only be entered if this has been selected in the settings (10.2.4Analysis settings

If you have set the slider to 1, the line for entering the density appears. Only one density is possible per run.

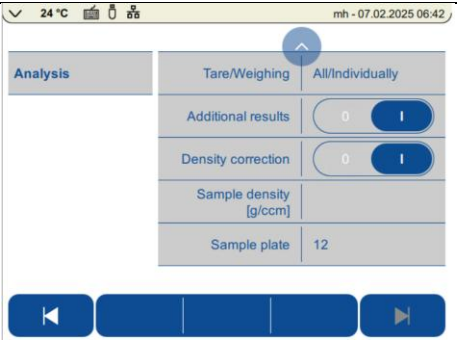
	<p>It is recommended to enter the sample density for inorganic samples, which have only a low loss on ignition and a large ash volume. For these samples, the density changes only slightly during the analysis, but the change in buoyancy at high temperatures cannot be neglected.</p> <p>This option is not needed for organic samples with very low ash levels, as the volume of ash is very small and the change in buoyancy is negligible. (The change in buoyancy of the crucibles is always effectively corrected for each sample tray pass using a reference crucible)</p>
---	--

6.2 Sample list

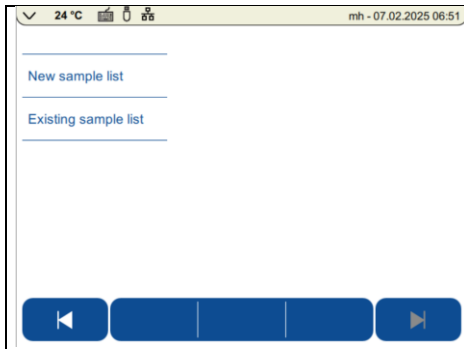

Weighing in prepASH

You can either create a new sample list or open an existing one

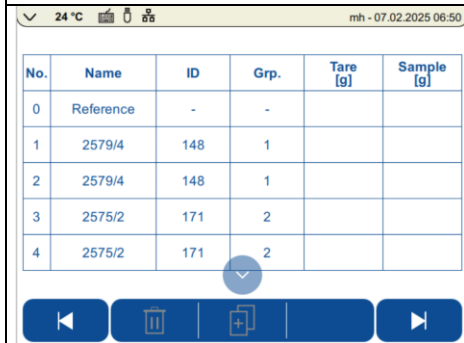

New sample list

Fill in the sample list. Click on the corresponding field to activate the entry.

ATTENTION: The samples must be activated, otherwise the position will not be approached during taring and will not be available for weighing.

If you do not assign a name, click on the item number.

Active positions: blue

Inactive positions: gray

No.: Crucible position

Name, ID: These 2 fields are available for identifying the sample.

Grp: the samples are assigned to a group for the statistical evaluation. (the same standards for the calibration of the volatile matter must be assigned to a group (14Appendix A: Carbon application

The weights are determined automatically by prepASH. Only items that are included in the sample list are approached.

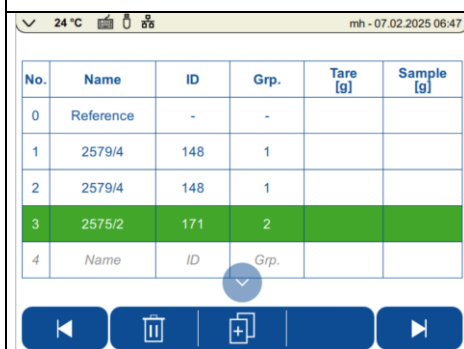

Copy/delete

Select the item to be deleted by clicking on the item number. The selected line is highlighted in green and can now be deleted.



Click on the recycle bin to delete the data record



Click on Copy to copy the data record. Then click on the number of the sample to be copied. This is possible for any number of items. To exit copy mode, click on the copy symbol again.

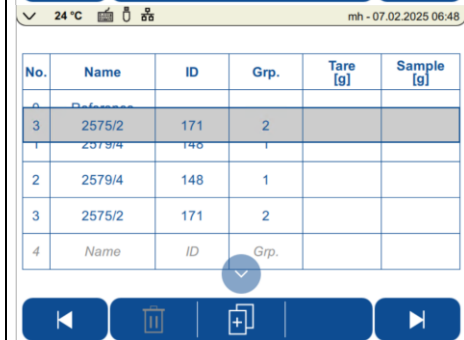

Once all samples have been entered, press the arrow to the right and you will be prompted to enter the file name. The software then automatically switches to taring. The procedure depends on the selected mode. Please follow the on-screen instructions.

Adapt existing sample list.
You can adapt an existing sample list. Click on the field to be changed and enter the new samples.

6.3 Weighing in prepASH and START

The weighing-in process and the prepASH user interface depend on the selected tare mode

6.3.1 Tara mode: all/individual

Tare values are all determined automatically, weighing is done individually under weight display.

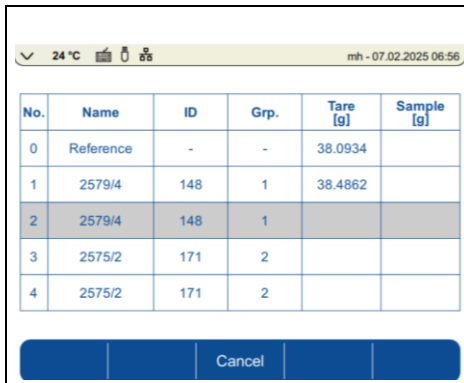

The tare values are all determined automatically

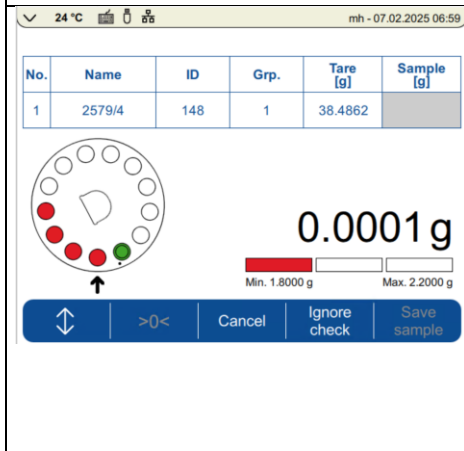

Now you can weigh in your samples directly in prepASH. The crucible is placed on the balance and is ready for weighing. The sample information for the corresponding position is displayed on the screen. The position on the disk is also displayed. Please note: the reference crucible (green) is required for buoyancy correction and remains empty. It is important that the reference crucible is clean and dry.

 The function enables weighing when the crucible is removed from the sample tray for filling the sample. The crucible is re-centered by lifting the sample tray

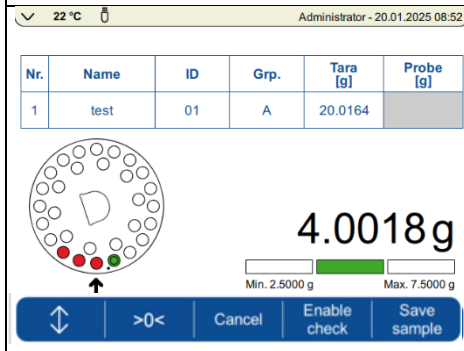

If you are working with Checkweigher, a bar and color will indicate whether you are within the weighing-in tolerance. If the weight is to be accepted even though it is outside the tolerance, click on "Ignore check". Such weigh-ins are noted in the log.

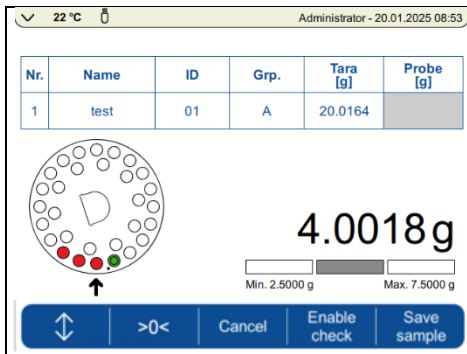

Press "Activate check" to reactivate the checkweigher.
Press "Save sample" to accept the initial sample weight and switch to the next sample. This is only possible when the weight value is stable and the initial weight is within the selected tolerance.

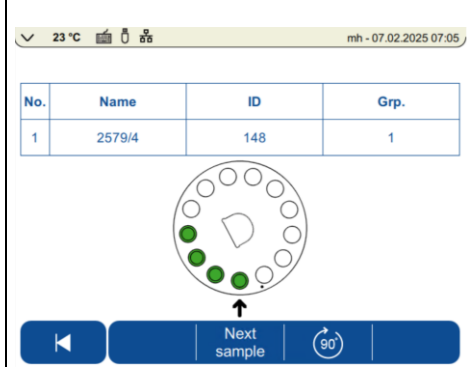

Once you have weighed out the sample, you can add ashing additives (such as sulfuric acid for sulfated ash) if required. These are not weighed, but you can use the "Weighing aid", where you can display the crucible to be filled in the front position.
You can move from position to position or rotate the disk by 90°.

6.3.2 Tara mode: all/all

Tare values are all determined automatically, the crucibles are filled using a pipette or measuring spoon, weights are determined automatically when prepASH is closed.

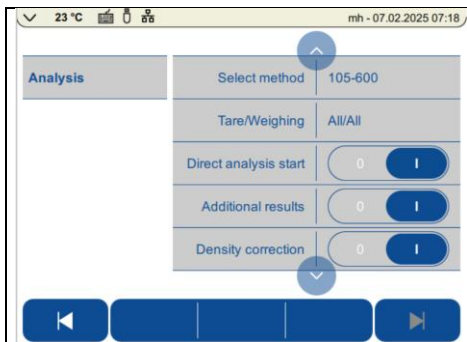

Select whether you want to start the analysis automatically after weighing in or whether you want to start it manually.
ATTENTION:

- If you are working with ashing additives, set the switch to off!
- If you are working with checkweighers and want to change weights outside the tolerance, set the switch to off as well, otherwise the program will start regardless of whether the tolerance is adhered to (and noted accordingly in the log)

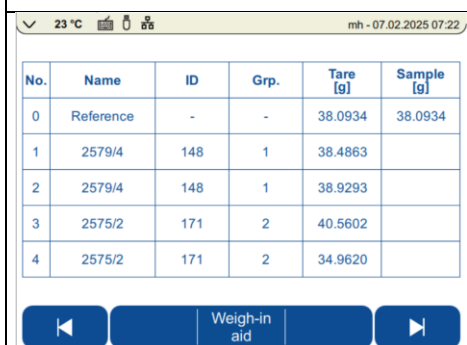

The tare values are all determined automatically

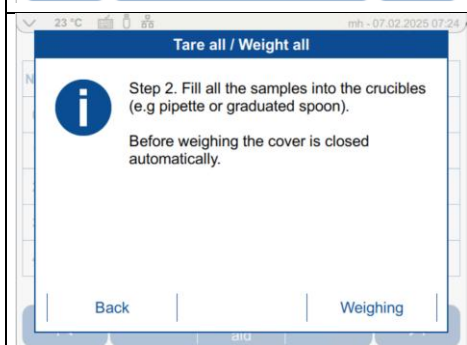

You can now fill the crucibles (e.g. using a pipette or measuring spoon) without weighing them.
You can do this outside or inside prepASH.
Start the weighing process. Whether the analysis then starts automatically or whether you have to trigger it manually depends on the settings you have selected.

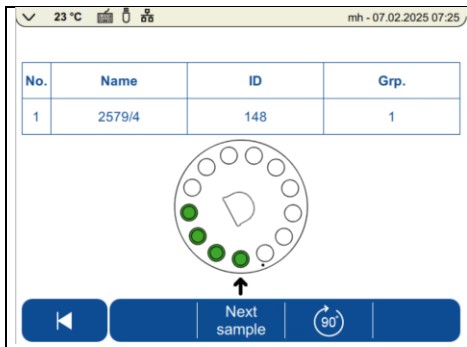

prepASH provides you with the "weighing aid", where the crucible to be filled is presented at the front. You can move from position to position or rotate the disk by 90°.

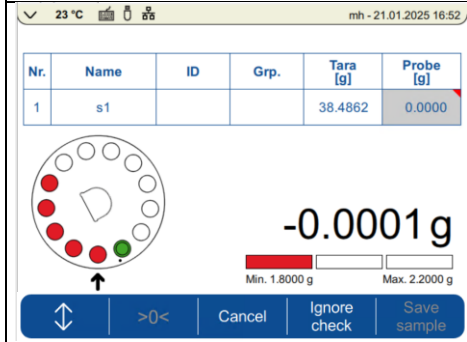
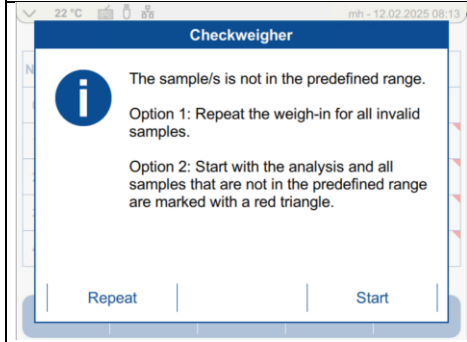

If you are working with checkweighers, you can choose whether you want to continue working if the weight is outside the tolerance range or whether you want to return to this position.

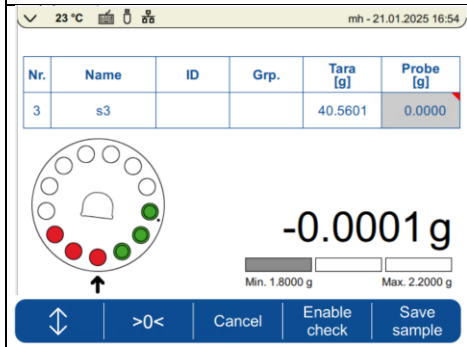

6.3.3 Tara mode: single/individual

Tare and initial weight are determined individually.

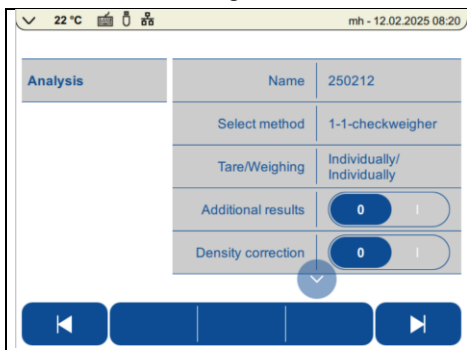

In single/individual mode, you work as on a balance, saving the tare value for each crucible directly before weighing in the sample.

	<p>Follow the on-screen instructions.</p>
	<p>Save the tare value.</p>
	<p>Fill in the sample and save the sample weight.</p>

6.4 Weighin in with prepSTATION

Make sure that balance, rotary unit and prepASH are connected to the PC.



Please refer to prepDATA manual for sample list, weighin in.

Open prepASH lid, insert the sample tray with filled crucibles.

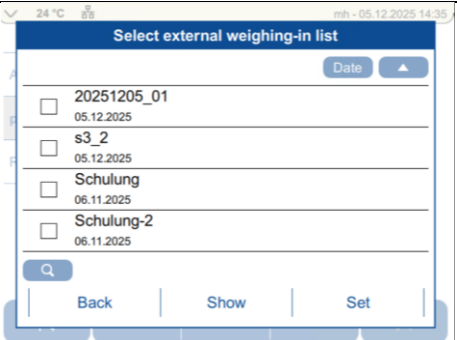
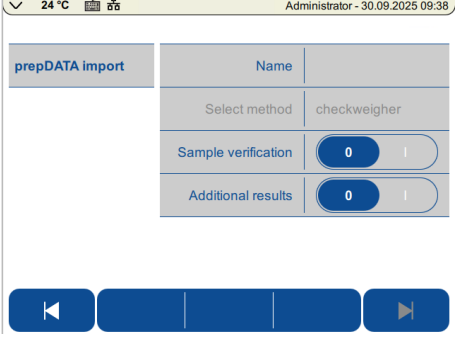

Enter Analysis

	<p>Choose prepDATA import</p>
--	-------------------------------

	<p>Select your weighing list. With “show” you can check that you have opened the correct weighing list</p>
	<p>Enter file name for data of analysis. (Method has been chosen in prepDATA) The reference crucibles is always checked as plausibility If the sample verification is chose a sample in the outer and inner circle is measured as well. The difference of prepSTATION and prepASH weight has to be smaller than 0.01 g (so sample verification could be critical for highly volatile samples) Other options such as additional results, density correction see chapt. 6.1.4 Additional results; 6.1.6 Enter the sample density</p>
	<p>Start the analysis</p>

6.5 Reuse weighing

Sample lists including the tara and sample weight can be reused for further analysis independently if they have been done in prepASH or prepDATA. You can run a second run with a new method.



Important:

- Make sure that crucibles stay in their positions (plausibility check for the reference crucible is done automatically, sample verification is not possible since the samples have allready already undergone thermal treatment.
- If the method of the second run has a checkweigher defined it will be ignored since initial weights don't correspond to original sample weights.

Possible applications for reusing weighing

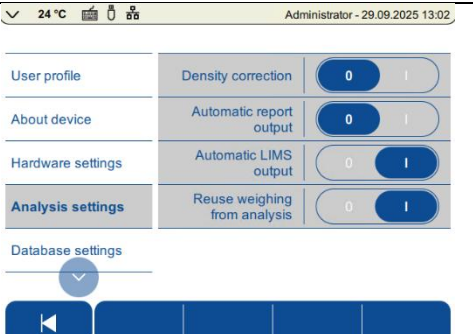
- E.g. having a drying step, followed by an external longterm treatment in a climate chamber (during this time prepASH would be free for other analysis), go back into prepASH for a second drying step followed by an ashing step
- First run: raw ash
second run: water or acid insoluble ash (after external water/acid treatment and filtration)

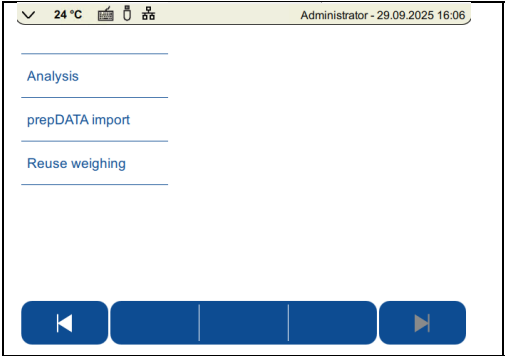
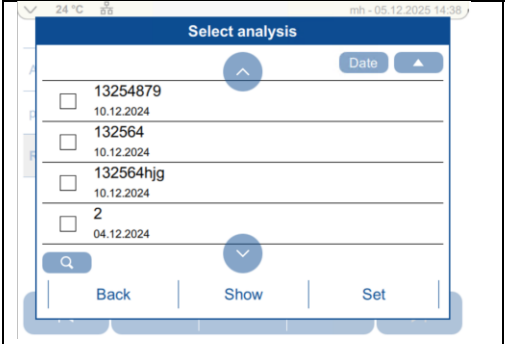
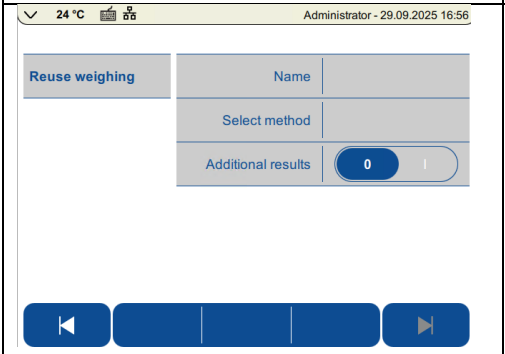



	<p>The reuse weighing lists has to be enabled in the “analysis stettings”</p>
---	---

	<p>Select "reuse weighing"</p>
	<p>Select previous run with the same samples</p>
	<p>Enter the file name of analysis Select the method (checkweigher will be ignored)</p>
	<p>Start the run</p>

6.6 During the measurement

During the measurement, you can switch between the graphical display and the results in tabular form. The type of calculation can be selected in the current display.

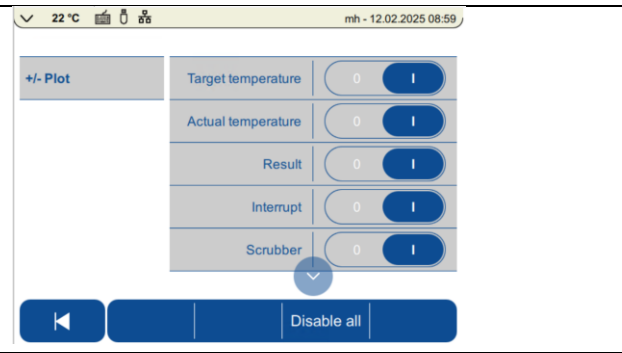
In prepDATA you can use "Live watch" to monitor the analysis from your PC.

	<p>You can cancel the analysis with "Cancel". Confirm the confirmation prompt.</p>
	<p>Select the display options Plot only affects the display, hidden data can be shown again at any time.</p>
	<p>Select what you would like to have displayed in the graphic. You also have the options "Show all" and "Hide all" to then selectively show them again.</p>
	

You have the option of choosing between graphics and

Show graphic <->

Change results table

Show results table

Sample

If you click on Sample, you can select individual sample

for the Autostop
the result of this sample is taken at the time when the last of the non-deactivated samples reaches the AS criterion. This sample is weighed normally again in all subsequent method steps.

- Remove from the measurement

These samples are no longer approached and can therefore no longer be analyzed.

ATTENTION: the deactivated sample is irrevocably removed from the measurement.

This is noted accordingly in the minutes:
Sample 1: AS was deactivated
Sample 3 was removed from the measurement.

Next step

Click "Next step" to cancel the current program step after a confirmation prompt and switch to the next step.

6.7 Program end

CAUTION

When the lid opening temperature selected in the program is reached, the furnace chamber lid is opened automatically.
Do not place anything on the prepASH.
The internal parts in the furnace chamber and the tray covers become hot, so take the necessary care.
Always use the holders supplied to remove the sample tray from the appliance.

**When removing individual crucibles, always use the crucible tongs supplied.
The ventilation runs until the set temperature is reached.**

The process at the end of the analysis depends on the selected settings. Here are some options:

- Automatic report printout
- Automatic saving to USB
- Display the results
- Add further calculations
- Attach remarks
- Active cooling

	<p>If user intervention is always required at the end of the run (additional results, comments...), the analysis page must be exited by clicking on the flag and you will be taken to the login screen. (If only one user is defined without a password, the system does not log out but switches to the main screen).</p> <p>If no manual intervention is required, this is done automatically at the end of the run</p>
---	---

6.8 Standby activated/User password

If standby is activated, the user must enter the password to unlock the screen again. The login screen appears (special cases are described below). The lock screen shows when user intervention is required.

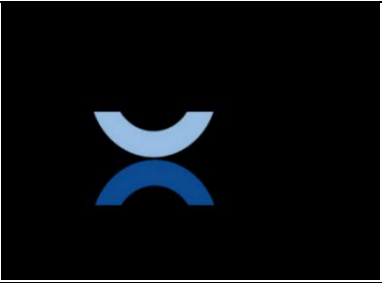
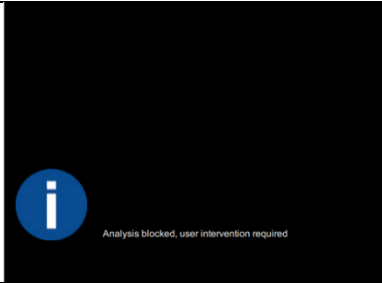
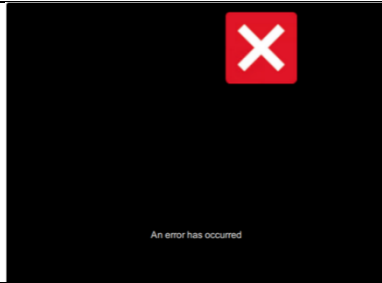
		
Standard situation	Information if an intervention by the user is necessary (analysis, temperature adjustment...)	If an error occurs.

As the start and end of a prepASH run may fall in different work shifts, the activation was set as follows:

Scenario 1:

End state: Standby with/or without password → As soon as prepASH is in the "End" state (lid open after analysis or annealing), the user is logged out when the touchscreen is touched. Any user can then log in and start a new analysis.

Scenario 2:

Run not completed: Standby with password, during analysis → PrepASH is blocked if you do not know the password. Attention, this also applies to the status at the end of the run if manual entries still have to be made (i.e. for all cases that have to be completed with the flag. These entries belong to the analysis and can therefore only be made by the user who started the run).

Exception:

The administrator password can be used to log in to all other users (except service and production). This means, for example, that the laboratory manager can complete a run.

7 Calculations

The following results are calculated during the analysis:

$$\text{Sample[g]} = (\text{Tara} + \text{Sample}) - \text{Tara}$$

$$\text{Residue[g]} = \text{weight [g]}$$

$$\text{Residue[\%]} = \frac{\text{weight}}{\text{initial Weight}} \times 100\%$$

$$\text{Residue}^{0/00} = \frac{\text{weight}}{\text{initial weight}} \times 1000^{0/00}$$

$$\text{Loss[g]} = \text{inital weight [g]} - \text{current weight[g]}$$

$$\text{Loss[\%]} = \frac{\text{initial weight} - \text{current weight}}{\text{initial weight}} \times 100\%$$

$$\text{current weight related to } W_n \text{ [\%]} = \frac{W_n - \text{current weight}}{W_n} \times 100\%$$

$$\text{Mean} \quad \bar{x} = \frac{\sum_{i=1}^n x_i}{n}$$

$$\text{Standard deviation} \quad \sigma = \sqrt{\frac{\sum_{i=1}^n (x_i - \bar{x})^2}{n(n-1)}}$$

8 Main menu



From the main menu, depending on your authorization, you can

- Adjusting the balance
- Annealing the crucible
- Open the database

Create methods (-> 0

- Create method / edit
- Import and export files

8.1 Adjusting the balance



You have defined the tare mode (external or external) in the settings
-> 0

Balance adjustment

In "external" mode, the Intelligent Calibration Mode (ICM) enables the calibration weight to be recognized in 10 g increments. This enables calibration with a 50 g or 100 g weight.

If you have selected "external def.", you are working with the specified weight!

<p>Remove the reference crucible, empty weighing pan and start adjustment</p> <p style="font-size: 24pt; text-align: center;">0.0000 g</p> <p>Mode: Extern Weight ID:</p> <p style="text-align: center;"> <input type="button" value="←"/> <input type="button" value=">0<"/> <input type="button" value="↻"/> <input type="button" value="Start"/> </p>	<p>Adjustment</p> <p>Follow the instructions on the screen.</p> <ol style="list-style-type: none"> 1. If the balance does not display 0.0000 g, press >0< 2. Start the adjustment by pressing the Start button. <ul style="list-style-type: none"> - The device carries out a zero-point measurement. <ul style="list-style-type: none"> - Place the calibration weight on the weighing pan 																														
<p>Place weight Suggesting: 50 g</p> <p style="text-align: center; border: 1px solid green; padding: 5px; font-weight: bold; color: green;">STABLE</p> <p>Mode: Extern Weight ID:</p> <p style="text-align: center;"> <input type="button" value="Cancel"/> </p>																															
<p>Justierung fertig Kal. Abweichung: -0.0041 g</p> <p style="font-size: 24pt; text-align: center;">100.0000 g</p> <p>Modus: Extern Gewichts-ID:</p> <p style="text-align: center;"> <input type="button" value="←"/> <input type="button" value=">0<"/> <input type="button" value="↻"/> <input type="button" value="Start"/> </p>	<table border="1" style="width: 100%; border-collapse: collapse;"> <tr> <td style="text-align: left;">12.02.2025 09:12</td> <td style="text-align: left;">Result</td> <td style="text-align: left;">Timeout stability</td> </tr> <tr> <td></td> <td>User </td> <td>mh</td> </tr> <tr> <td></td> <td>Mode </td> <td>Extern</td> </tr> <tr> <td></td> <td>Weight ID </td> <td></td> </tr> <tr> <td></td> <td>Cal. weight </td> <td>50 g</td> </tr> <tr> <td></td> <td>Balance temp. </td> <td>19.2 °C</td> </tr> <tr> <td style="text-align: left;">08.01.2025 11:48</td> <td style="text-align: left;">Result</td> <td style="text-align: left;">Cancelled by user</td> </tr> <tr> <td></td> <td>User </td> <td>mh</td> </tr> <tr> <td></td> <td>Mode </td> <td>Extern</td> </tr> <tr> <td></td> <td>Weight ID </td> <td></td> </tr> </table> <p style="text-align: center;"> <input type="button" value="←"/> <input type="button" value=">0<"/> <input type="button" value="↻"/> <input type="button" value="Start"/> </p>	12.02.2025 09:12	Result	Timeout stability		User	mh		Mode	Extern		Weight ID			Cal. weight	50 g		Balance temp.	19.2 °C	08.01.2025 11:48	Result	Cancelled by user		User	mh		Mode	Extern		Weight ID	
12.02.2025 09:12	Result	Timeout stability																													
	User	mh																													
	Mode	Extern																													
	Weight ID																														
	Cal. weight	50 g																													
	Balance temp.	19.2 °C																													
08.01.2025 11:48	Result	Cancelled by user																													
	User	mh																													
	Mode	Extern																													
	Weight ID																														

8.2 Annealing

No sample lists or weights are required to anneal the crucibles. Define the temperature profile in an annealing method (-> 5 Create method / edit). To do this, select a holding temperature that is at least equal to the ashing temperature.

 **NOTE**
 Place the crucibles to be annealed in the prepASH



Click on the annealing icon.

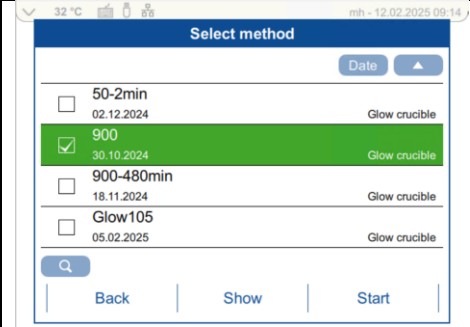

Select the smoothing method and start the program. You have the option of displaying the calibration method in advance.

8.3 Database/Files



You can access the database directly from the main window.

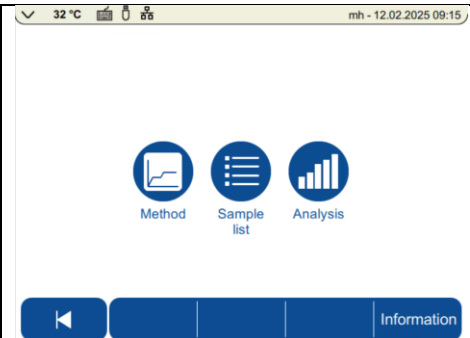





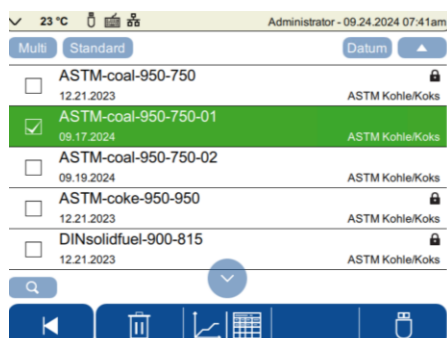

There you will find the folders Method, Sample list and Analysis. Open it by clicking on the corresponding icon.



Select the desired file.



Now you can:

	search for files, * can be used as wildcard/joker character.
	delete the file
	display the file, either in tabular form or as a graphic, depending on the type
  	Select the destination of the output in the settings (-> 10.2.9Report ; Select the destination of the report output here)

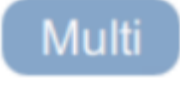

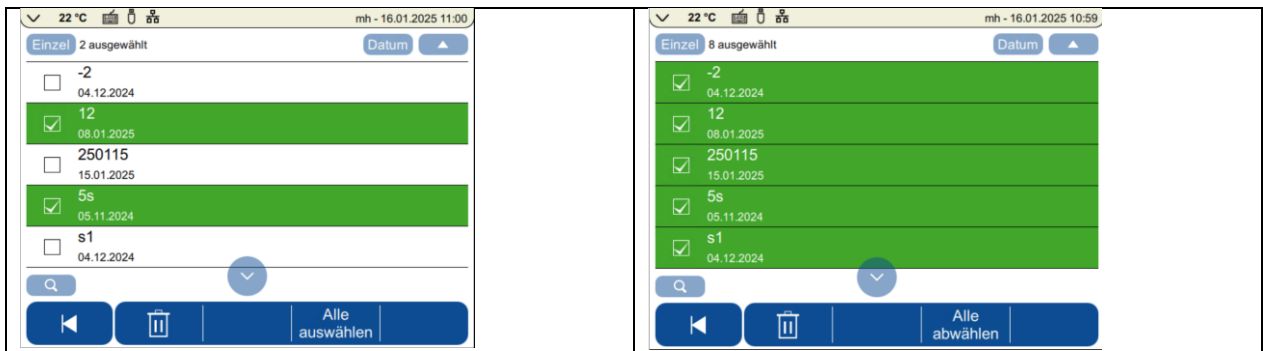





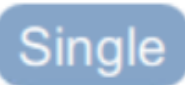
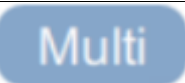

	Files can also be deleted as a batch. To do this, select "multi" Now you can <ul style="list-style-type: none"> - Select the desired files by clicking on them - Or select all files
---	--



	The selected files can now be deleted
---	---------------------------------------

8.4 Import/Export

	You can access the import and export functions directly from the main window. A USB stick must be connected for this. Files are exported to the USB stick and also imported from the USB stick. Please note that the methods are also stored here in the ASTM, Glow, Standard and Temp. folders, depending on the type.
	Select "Single" to import/export a single file. Select the desired file.
	Files can also be processed as a batch. To do this, select "multi" You can now select and deselect all files or select several files.

	  <p>You can import methods and sample lists from a USB stick. This makes it possible to transfer them from one prepASH to another.</p>
	  <p>Method, sample lists and analysis can be exported.</p>
	<p>Search for files. You can use * as a wildcard/joker character.</p>
	<p>Exporting the selected files</p>  <p>Datenexport erfolgreich!</p>
	<p>Importing the selected files</p>
	<p>Display the file, either in tabular form or as a graphic, depending on the type</p>

9 Data transfer and prepDATA 2.0

prepDATA is designed for Windows 7 / 8, 10 and Windows 11 all with 32 or 64.

There are several ways to transfer data from prepASH to a PC. With prepDATA, the results can also be viewed, printed out and saved in various formats.

9.1 Concept/structure

prepData accesses the prepASH data server via an established network connection. All data traffic is encrypted

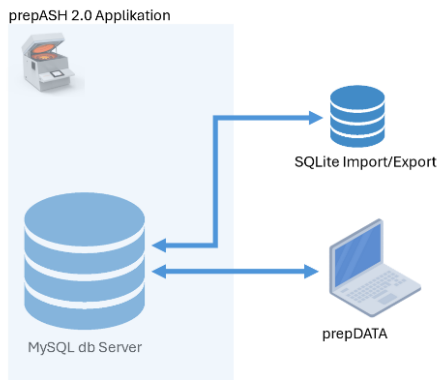

9.2 Recommendations

It is recommended to establish the data query via prepDATA exclusively via LAN. If no LAN is available, this can also be ensured via USB stick. In this case, an encrypted SQLite data record is generated.

! NOTE

You can find more information on connecting prepASH with prepDATA in the prepDATA manual.

! NOTE

You can find out how to install a printer on prepASH in chapter **Fehler! Verweisquelle konnte nicht gefunden werden.Fehler! Verweisquelle konnte nicht gefunden werden.**

9.3 LIMS & Data Sharing

As an alternative to data exchange via USB flash drive, data can also be stored on a network drive.

This requires a stable network connection that allows access to an assigned data directory. This usually requires the support of the IT administration, which creates the directory with the appropriate access rights.

After establishing network access, reports (PDF) and LIMS files (JSON) can be stored in the assigned directory.

9.3.1 Setting Up Data Sharing

! Note

For data sharing, the network access for prepASH must be activated and established.

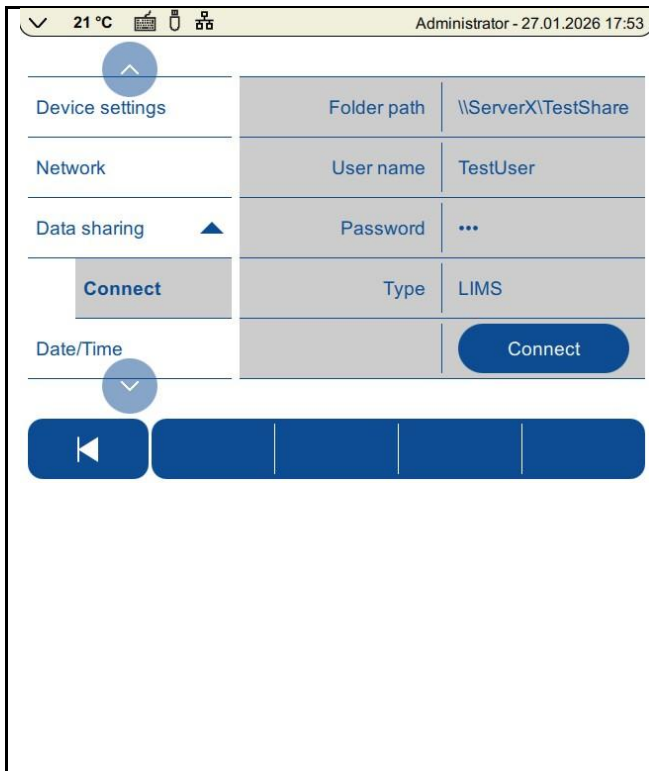

Required settings to connect a shared network folder:

Folder path:

Enter the assigned folder directory
 \\ServerName\Shared Directory\

Note: The folder path includes only the server name and the shared directory. Do not enter the entire path

Username:

Enter the assigned username (usually provided by the IT admin)

Password:

Enter the assigned password (usually by the IT admin)

Type: Defines which records are stored in the assigned directory:

- LIMS: Only the LIMS file
- Report: Only the Report
- LIMS/Report: LIMS file and the report

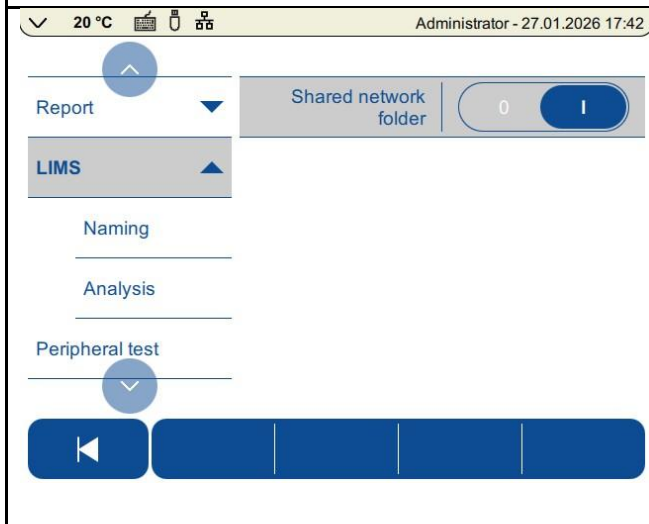

LIMS related settings

Shared Network Folder:

Must be enabled for a LIMS file to be stored in a shared network folder.

Naming:

The time information (date/time) is added to the file name as a prefix or suffix

Example: 20250729125513_analysis1.json

Analysis:

Content of the LIMS data

Note: For more information about the LIMS record, please contact our customer service

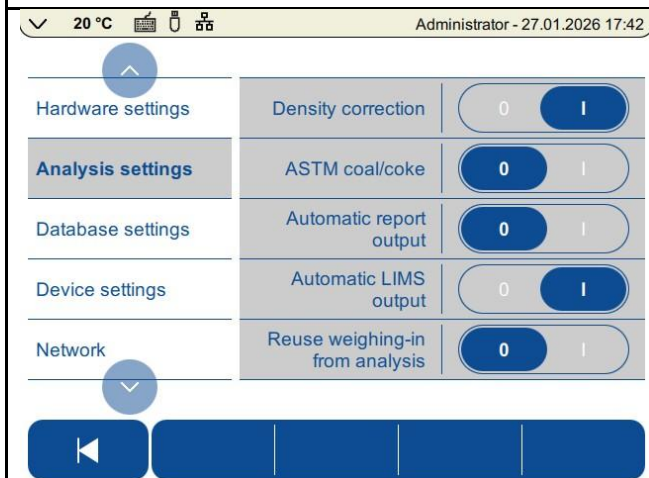

Optionally, the reports and the LIMS data can be transferred manually or automatically

Automatic LIMS output:

- Switch to 1:
 After the analysis, a LIMS record is automatically created and stored in the shared network folder

- Switch to 0:
 After the analysis, an additional button is displayed allowing to save the LIMS record to the assigned shared network folder

20 °C Administrator - 27.01.2026 17:43

Multi Date ▲

<input type="checkbox"/>	105_fan100_2	08.04.2024
<input type="checkbox"/>	105_fan100_3	09.04.2024
<input type="checkbox"/>	105_fan100_4	09.04.2024
<input checked="" type="checkbox"/>	105_fan50	08.04.2024
<input type="checkbox"/>	105_fan50_wasser	09.04.2024

Q

◀ ◉ 📁 ↗

Import/Export:





Alternatively, the analysis can also be transferred manually to the assigned network folder via the import/export function of the home screen

To do this, the <Shared Network Folder> switch under the menu item <LIMS> must be activated.

10 Utility programs

10.1 Audit trail

The prepASH records all operator inputs, changes and other processes. Each of these processes is assigned a fixed, unique identification number.

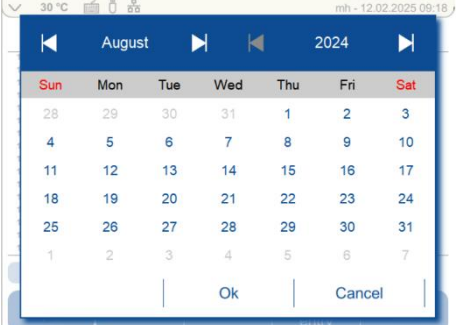
	<p>The entries can be visualized and saved by starting the <Audittrail></p>
	<p>Export the audit trail to a USB stick. The data is encrypted and can only be viewed again with prepDATA.</p>
	<p>The audit trail data is stored on the device and cannot be manipulated. However, the administrator and the service department have the option of making manual entries. This also allows entries to be made that cannot be recognized by the software, e.g. change of location, cleaning of the extraction system....</p>
	<p>By clicking on the search function, the entries can be searched for easily, using a calendar.</p> <p>Dates that have entries are marked accordingly by a triangle.</p> 



10.2 Settings

Depending on your access authorization, various setting options are available to you. Buttons with a gray background are deactivated for you.

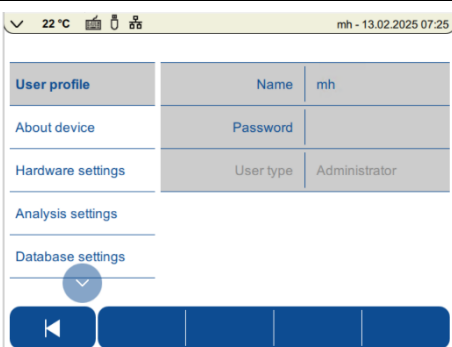
10.2.1 User profile

	<p>Here you can see your name and access type and you can change your password.</p> <p>Only the administrator can create user profiles -> 10.2.1 User profile</p>
---	--

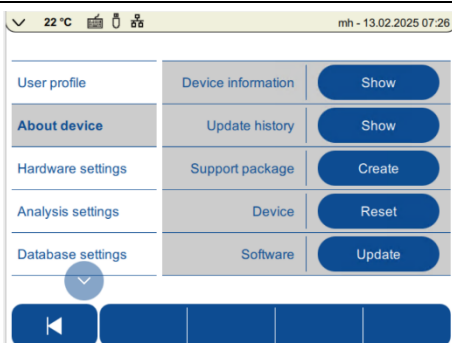
10.2.2 About the device

	
---	--

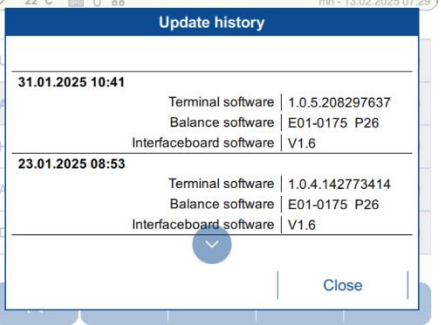
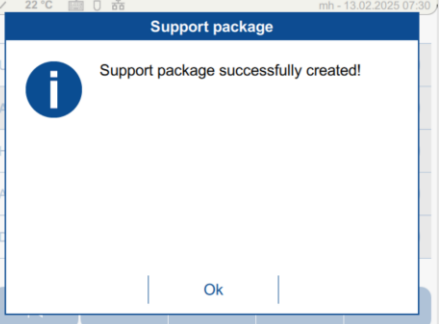
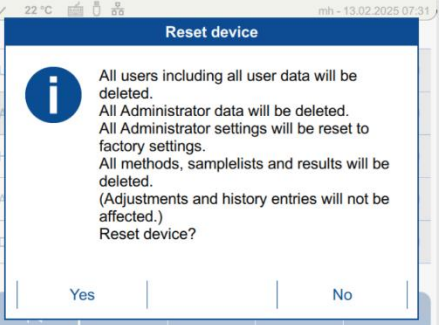
	<p>Device information Here you will find the device information such as type, serial number, software versions of prepASH, the balance and any other components.</p>
	<p>Update history Here you will find information about updates</p>
	<p>Support package Create a support package here. Connect a USB stick and the support package will be saved on it. Make this available to the service. This enables the service to find or exclude possible sources of error.</p>
	<p>Reset device Attention: when the device is reset, all data is deleted. -> Screen information. The reset can only be carried out by the administrator.</p>
<p>Updating the software: is described in a separate chapter: 12 Update prepASH software</p>	

10.2.3 Hardware setting

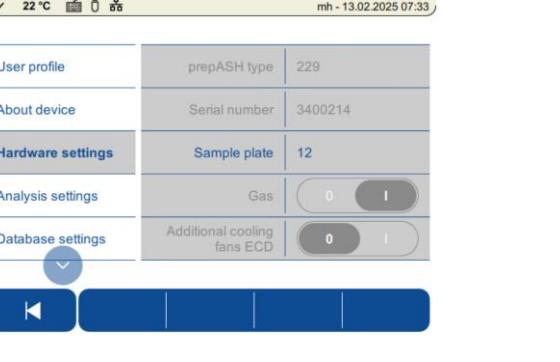
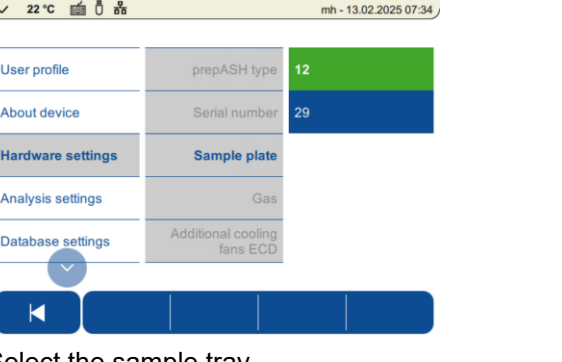
	 <p>Select the sample tray.</p>
---	---

10.2.4 Analysis settings

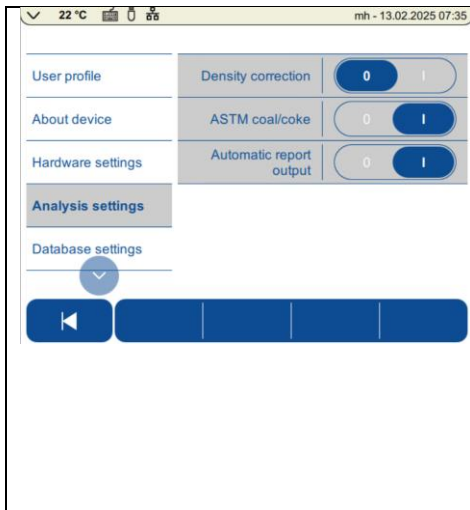

Density correction:

Select whether the density correction of the sample should be available during the analysis.

When activated, it can be determined for each run whether a density correction of the sample should be taken into account or not.

This is not necessary for organic samples with low ash volumes.

ASTM: Methods with a predefined sequence are provided for carbon analysis (proximate incl. volatile matter). You then select the parameters as for standard methods in the method creation.

Select whether you want an automatic report output at the end of the run (or whether the analysis should be checked on the prepASH beforehand).

10.2.5 Database settings

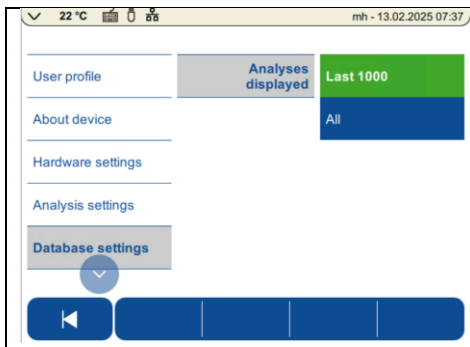

Select whether all data is displayed or only the last 1000.

10.2.6 Device settings

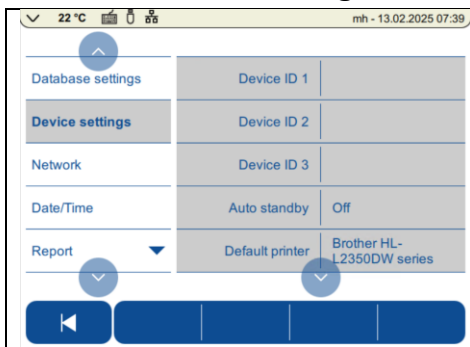

Here you can add additional identification codes to your prepASH (e.g. inventory number, test device number, department, etc.).

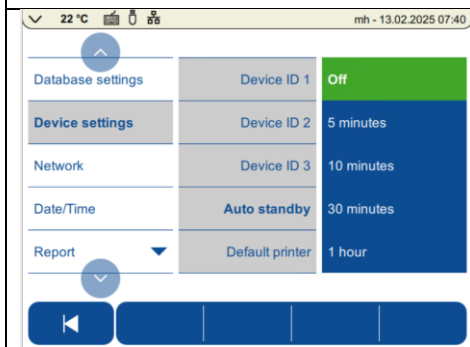

Specify whether and when prepASH switches to standby mode. If the user has a password, this must be entered again to exit standby mode. If the device switches to standby mode during the analysis, the measurement is continued immediately. (see also 6.8 Standby activated/User password)



You can also switch to standby mode manually at any time using the yellow button in the swipe-down menu.

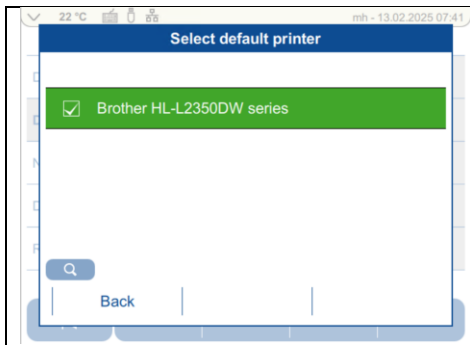

Set the default printer for the log output.

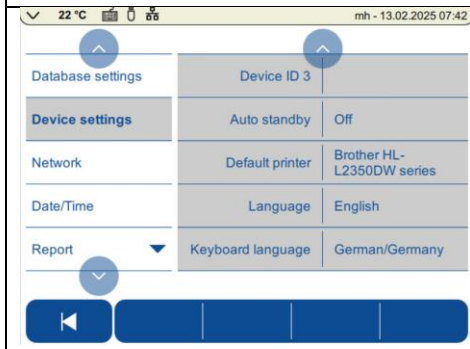

Select the dialog language and the keyboard settings.

10.2.7 Network

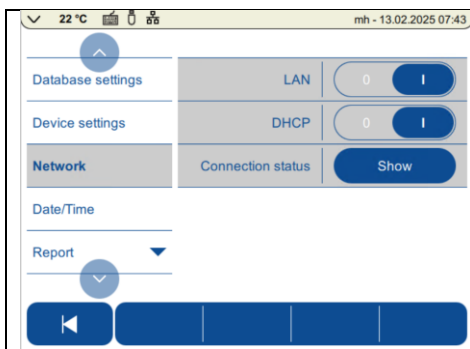

To connect prepASH to the network, the details must be discussed with the network administrator.

The <DHCP> setting is usually active (IP address is assigned by a DHCP server)

In the event that a static IP address must be used, the network administrator knows the settings of the IP address, the subnet mask and the default gateway.

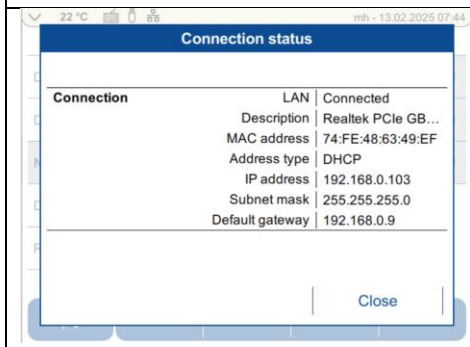

The <Show connection status> button can be clicked to check the network factory status.

10.2.8 Date and time

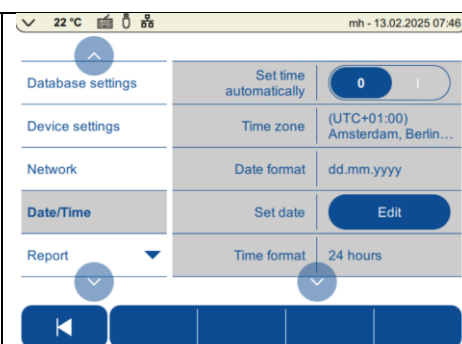
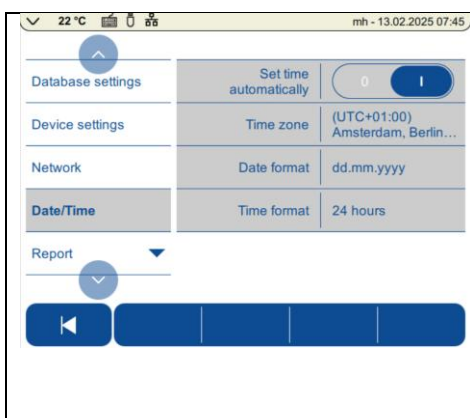

If the automatic time setting is not selected, you can select the date and time manually.

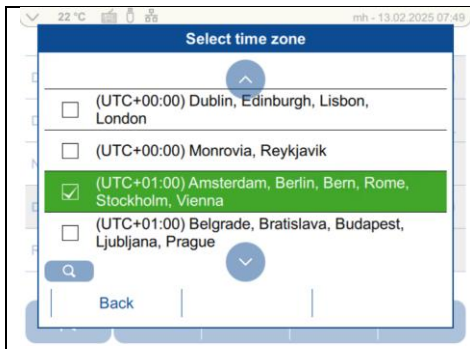

Time zone: Select your time zone

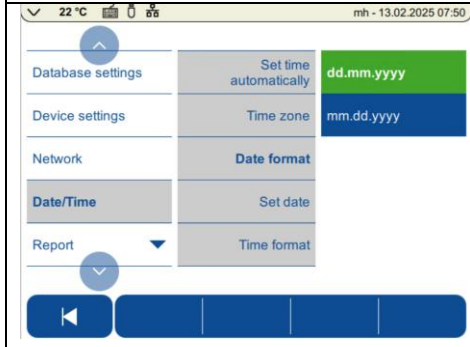

Select the date format

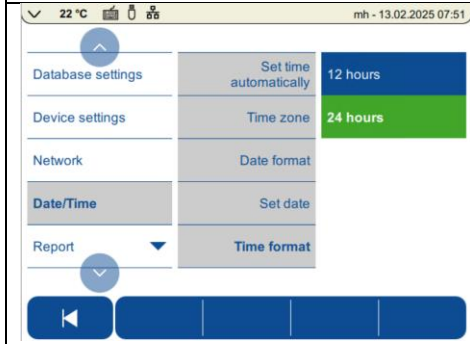

Select the format of the time display.

10.2.9 Report

Three report types are available to you: the analysis, the method and the sample list. You define the header and footer for all three types.

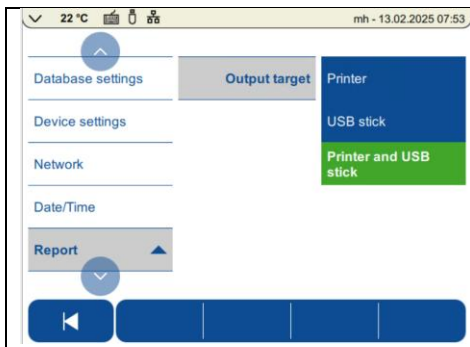

Select where the report should be sent to.

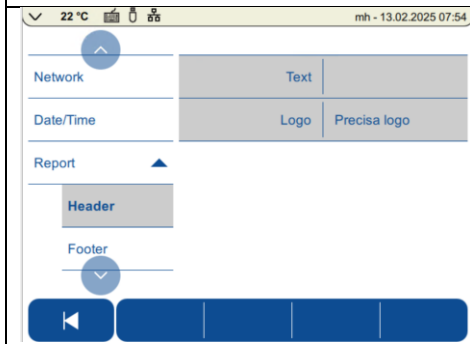

Define the header.
You can define the logo and text.

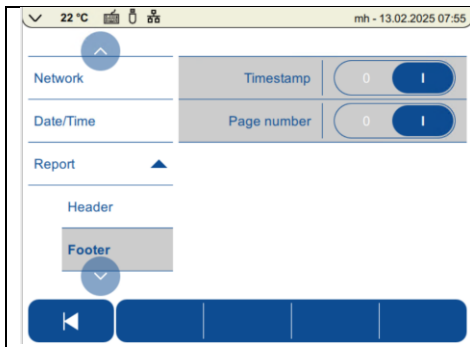

Determine whether the current time stamp of the printout and page number should be displayed in the footer.

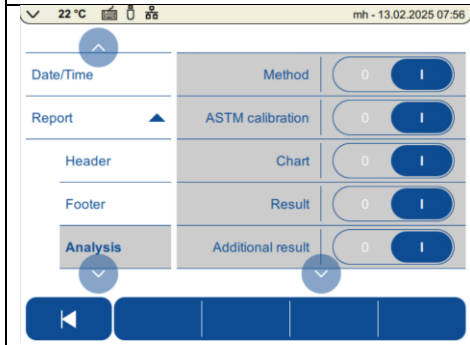

Specify which information on the analysis should be included in the log. Scroll with the right arrow to display further items.

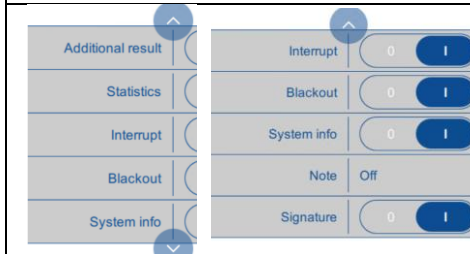

Several options are available for annotations and the annotation screen.

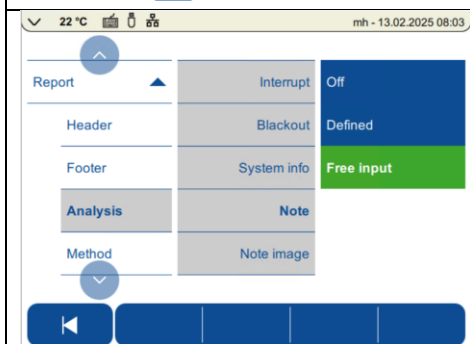

Default: in the next line you can enter the text that will then appear on each log.

Note	Defined
Note text	note fix mh

Free input: A comment field is provided so that you can add a comment after the analysis
ATTENTION: the analysis is not automatically completed here. This is particularly important when working with the standby option (6.7Program end6.76.8 Standby activated/User password

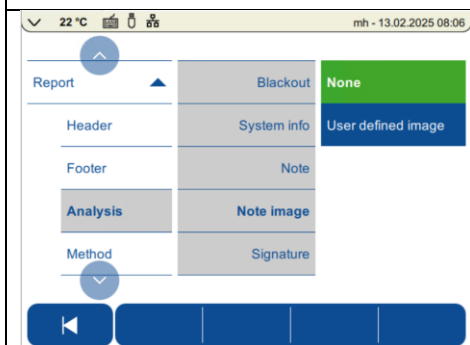

You have the option of inserting your own fixed image.

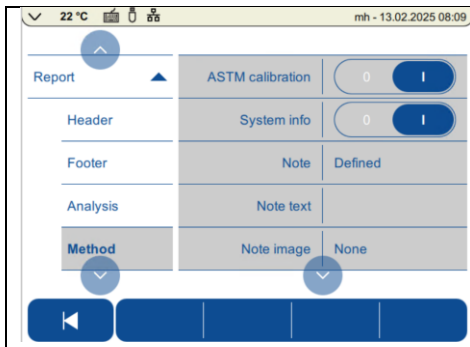

Select which information about the method should be included in the method report.

Note and annotation image -> see above. Analysis

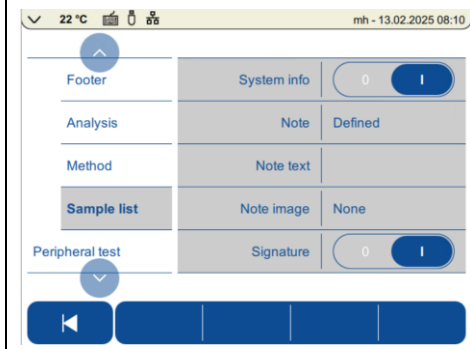

10.2.10 Periphery test

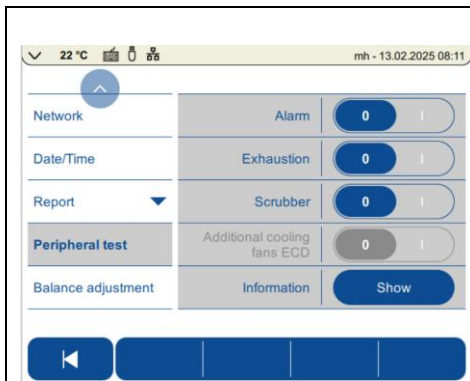

Here you can control the peripheral systems for test purposes.

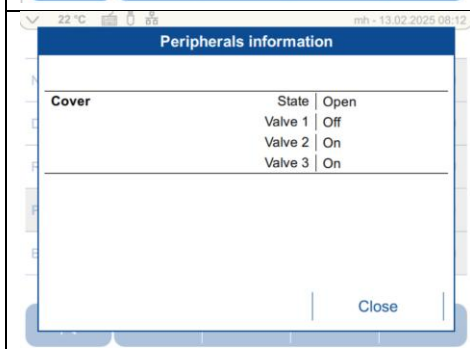

10.2.11 Balance adjustment

	<p>Select the balance adjustment mode.</p> <p>External: the weight is automatically recognized in 10 g increments. You can therefore use a 50 g or 100 g weight.</p> <p>Externally defined: here you can define your certified weight with specified weight and ID.</p> <table border="1" data-bbox="715 376 992 504"> <tr> <th>Mode</th> <th>Extern defined</th> </tr> <tr> <td>Weight [g]</td> <td>50.0001</td> </tr> <tr> <td>Weight ID</td> <td>4578-51</td> </tr> </table>	Mode	Extern defined	Weight [g]	50.0001	Weight ID	4578-51
Mode	Extern defined						
Weight [g]	50.0001						
Weight ID	4578-51						

10.3 User administration

prepASH is delivered with an administrator without a password. Only one administrator can be defined. You can change the name and set a password in the user profile (User profile)

10.3.1 Create

The administrator can create "Standard users" and "Restricted users" and a quality manager (QM)

	<p>Enter the name of the user.</p> <p>You can also assign a password here, which the user can then change in the user profile.</p> <p>If "Password required" has been selected, it is mandatory to assign a password here.</p> <p>Under Type, you specify the authorization status. If a quality manager already exists, this option is no longer displayed.</p>
<p>Lock = Administrator</p>	<p>Administrator and QM only exist once per device. The authorization level can be identified by the symbol.</p>
<p>Check mark = QM</p>	
<p>No symbol = standard Users</p>	<p>Any number of users can be defined.</p>
<p>Prohibition sign = Restricted user</p>	

10.3.2 Delete

	<p>Select the user to be deleted (green) and delete it by clicking on "Delete".</p> <table border="1" data-bbox="699 1774 1040 1877"> <tr> <td>Name</td> <td>mr</td> </tr> <tr> <td colspan="2" style="text-align: center;">Delete</td> </tr> </table> <p>The user is deleted after a confirmation prompt.</p> <p>The administrator cannot be deleted.</p>	Name	mr	Delete	
Name	mr				
Delete					

10.3.3 password

The screenshot shows a mobile application interface for password configuration. At the top, there is a status bar with a temperature of 22°C, signal strength, and the time 08:23 on 13.02.2025. Below the status bar, there are two columns of settings. The left column contains 'Create', 'Delete', and 'Password' (with a dropdown arrow). The right column contains 'Password required' (with a toggle switch set to 'I'), 'Expiration time [day]' (180), 'Login attempts' (3), and 'Min. length' (2). Below the settings, there is a blue bar with a back arrow and four empty slots.

Specify whether a password is mandatory.

A password can also be set if this is not required.

Here you can also define expiry times, number of login attempts and minimum lengths.

The screenshot shows a mobile application interface for password configuration. At the top, there is a status bar with a temperature of 22°C, signal strength, and the time 08:25 on 13.02.2025. Below the status bar, there are two columns of settings. The left column contains 'Create', 'Delete', and 'Password' (with a dropdown arrow). The right column contains 'Uppercase letter' (with a toggle switch set to 'I'), 'Lowercase letter' (with a toggle switch set to 'I'), 'Numerical digit' (with a toggle switch set to 'I'), and 'Special character' (with a toggle switch set to 'I'). Below the settings, there is a blue bar with a back arrow and four empty slots.

Specify the format of the password.

11 Service tools



11.1 Mechanical settings

In the service tools, you will find the icon for the mechanical settings (if you are authorized to do so).

<p>Please follow on-screen instructions. Vertical distance depends on the used sample tray for 29 or 12 samples (31 mm resp. 20 mm)</p>	

	<p>Adjust the positions by the outer buttons for rough adjustment, and the inner buttons for a fine adjustment.</p>
<p>Rotation: Correct the rotation of the sample tray until the weighing pan is exactly below the reference hole of the sample tray (check without crucible).</p> <p>Down - Up (vertical alignment): Adjust the height of the sample tray until the surface of the sample tray is 31 mm (29 samples) or 20 mm (12 samples) above the weighing pan (-> figure above).</p> <p>Out - In (horizontal alignment): Correct the position of the balance until the weighing pan is exactly below the reference hole of the sample tray (check without crucible).</p> <p>Back (arrow): The reference position is approached and the plug-in is exited.</p> <p>Reset: You are asked whether the offsets should be reset. If yes, the reference position is deleted (also in the DB) and moved to the limit switches.</p>	

Reference position:

The system moves to the current reference position

The new reference position is saved and a message displayed. The new settings must be saved for them to be applied. The new settings are saved

11.2 Gas flow

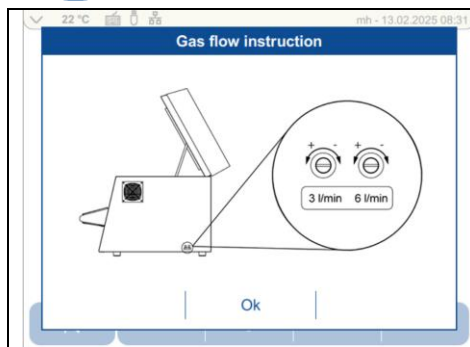

The prepASH has two valves for the process gases.

3 l/min and 6 l/min, these are selected in the method steps and enable 0, 3, 6 or 9 l/min.

If necessary, regulate the flow rate of the valve (right-hand side prepASH).

Increase the flow rate by turning it counterclockwise.

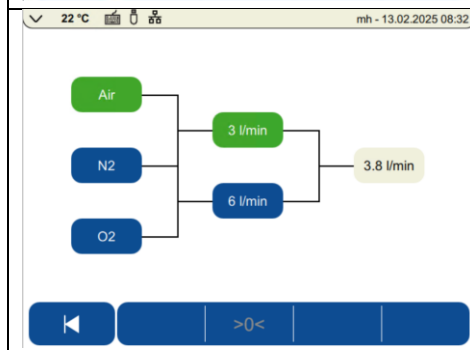

To do this, select the gas and the valve.

If the flow does not display 0 when the valve is closed, set the display to zero with <0>.

11.3 Temperature calibration and adjustment

Temperature calibration:

The temperature calibration is only used to check whether the temperature is within the tolerance range; according to the prepASH specifications, this is $\leq \pm (1\% + 2\text{ }^\circ\text{C})$, e.g. $\pm 3\text{ }^\circ\text{C}$ at $100\text{ }^\circ\text{C}$ and $\pm 10\text{ }^\circ\text{C}$ at $800\text{ }^\circ\text{C}$.

Calibration can be carried out by all users. The calibration contains at least one calibration point but can also contain several points.

Adjustment:

The temperature adjustment was carried out at the factory during the manufacture of the prepASH. There is normally no need to readjust the prepASH at the customer's premises.

The adjustment can only be carried out by the administrator, QM or Service. The adjustment contains exactly 2 adjustment points.

11.3.1 Method for temperature calibration/adjustment

A predefined method ($100\text{ }^\circ\text{C}$ and $800\text{ }^\circ\text{C}$) is available for calibration and adjustment. If other temperature adjustments are useful for your application, create a corresponding method. Please note that the upper temperature should be in the range of the incineration temperature or higher.

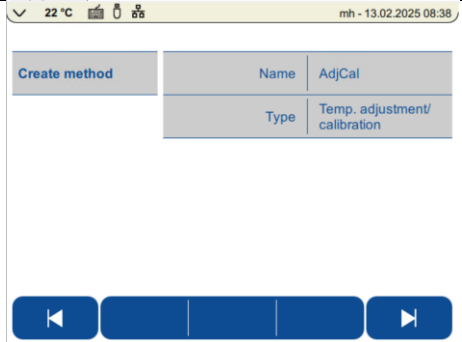
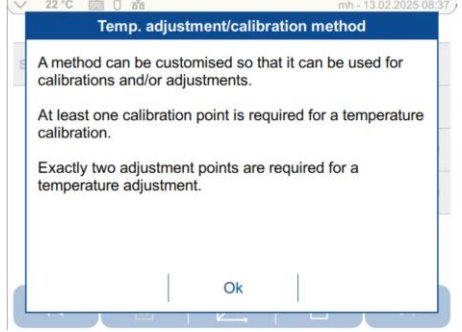
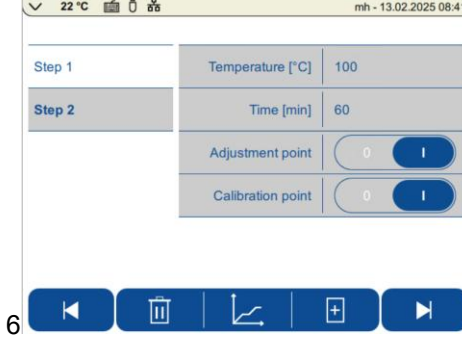
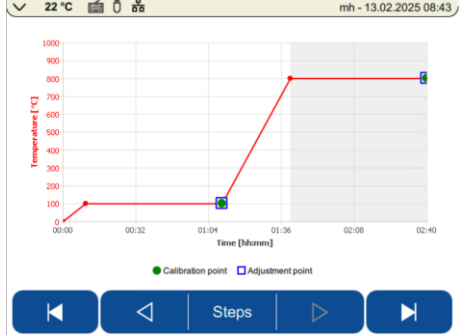
	<p>Select the type: Temp. adjustment/calibration</p>
	<p>If you select both calibration and adjustment, you can decide at the end of the measurement whether you want to carry out an adjustment or not.</p> <p>If only calibration is carried out (by the user) and the values are not within the standard, the prepASH must be cooled down and the temperature run repeated for adjustment.</p>
	<p>Set the adjustment/calibration point at the end of the holding temperature (not at the ramps).</p> <p>The temperature should be constant for at least 30 minutes (preferably 60 minutes).</p> <p>The external value can then be entered after the selected time has elapsed. However, the temperature is held until this happens.</p>
	

11.3.2 Temperature calibration



To perform a temperature calibration or adjustment, you need a thermometer with a permissible temperature of up to 1000 °C and a recommended tolerance $\leq \pm (1\% + 2 \text{ }^\circ\text{C})$. The temperature sensor must have a diameter of less than 3.2 mm and a minimum length of 16 cm. Select the temperature in the service tool.

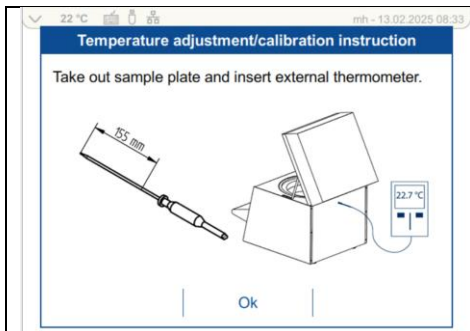

Remove the screw on the back of the prepASH so that you can insert the temperature sensor through the thermometer opening into the furnace chamber, see also chapter 2.2.1 , position 11.
The insertion depth into the chamber is 155 mm. The easiest way is to mark the position on the sensor.

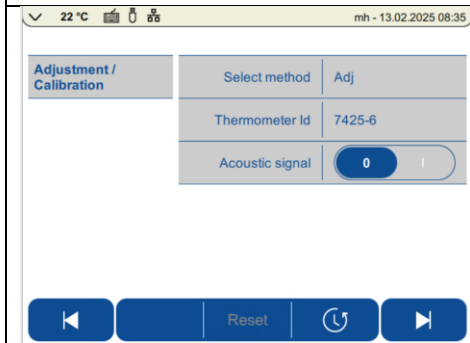

Give the method a name, add the identification of your thermometer and select whether you want an acoustic signal at the end of the holding temperature.

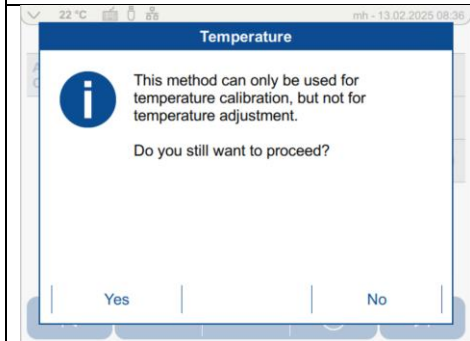

If you start with a method that can only be calibrated or adjusted, you will be notified of this.

Confirm to start the temperature measurement

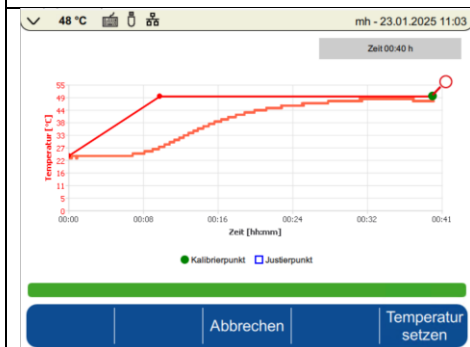

After the selected time has elapsed, the "Set temperature" button is enabled. Click on it to enter the temperature that you read on the external reference thermometer. (However, the temperature is held until this happens).

Messpunkt	Soll [°C]	Ist [°C]	Thermometer [°C]
Kalibrieren	50	48.1	49.0

Buttons: Kalibrieren, Abbrechen, Justieren

Values are only accepted within +/- 20 % of the setpoint temperature (plausibility check). If the external value is outside this range, first check whether the external probe is inserted correctly. Otherwise, check which temperature probe is causing the problem.

Depending on whether further temperatures are to be measured, the software now switches to the next temperature step or the table with the temperature values appears.

Depending on the method setting, the values can now be used for calibration (only note in the history) or adjustment.

It is also possible to cancel the calibration/adjustment.

The screenshot shows the main interface of the prepASH 2.0 2xx. At the top, the current temperature is 47 °C, and the date and time are 23.01.2025 11:05. Below this, there are two status bars: 'Deckel öffnet bei 400°C' and 'Deckel schließt bei 40°C'. The main content area features a table with calibration data:

Messpunkt	Soll [°C]	Ist [°C]	Thermometer [°C]
Kalibrieren	50	48.1	49.0

Below the table, the text 'Abkühlung abwarten' is displayed. At the bottom, there is a dark blue navigation bar with four icons: a printer, a refresh symbol, a flag, and a thermometer.



If calibration/adjustment has been performed, you can print/export the report (depending on the settings)



Here you have access to all previous calibrations/adjustments at any time



You leave the temperature page and are automatically logged out.

12 Update prepASH software

12.1 Preparation

The following preparations are required to update the software:

- Download the latest prepASH software from the Precisa website.
- Unzip file and copy to USB stick

12.2 Executing the update

- Insert the prepared USB stick into prepASH.
- Call up the <Settings><About the device> menu
- Start the update process by pressing the <Update software> button.
- Once the process is complete, the application restarts.

Note

Updating the software requires appropriate rights. (e.g. administrator). See also User management

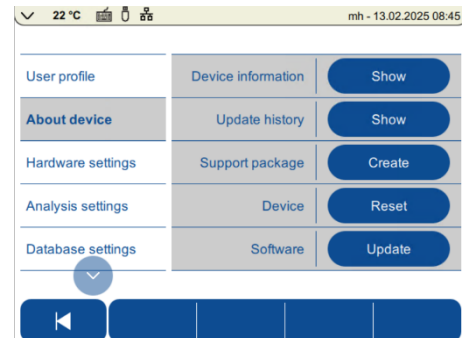

13 Maintenance and service

⚠ DANGER

Disconnect the ashing appliance from the mains during all maintenance work (pull out the mains plug). Secure the device against accidental switch-on.

To ensure operational safety, the ashing appliance must be checked for proper condition at least every four years by a specialist from your service center.

Other maintenance work was limited to regular cleaning.

13.1 Housing

The outside of the housing can be cleaned with a damp cloth.

13.2 Furnace chamber

Remove the internal parts (sample tray, crucible, weighing pan) and then clean the furnace chamber with a vacuum cleaner. Be careful with the sensitive insulation and the heating elements. Avoid damage caused by the suction tube.

⚠ NOTE

The high temperatures can lead to cracks in the insulation inserts. This is normal.

13.3 Chimney

⚠ NOTE

The chimney must be cleaned every six months to ensure adequate extraction from the stove compartment.

13.3.1.1 Tool

Socket wrench for hexagon socket SW7
Phillips screwdriver

13.3.1.2 Removing the hood

1. Open the lid via the touchscreen using .
2. Detach the cover from the lid by removing the two bolts.

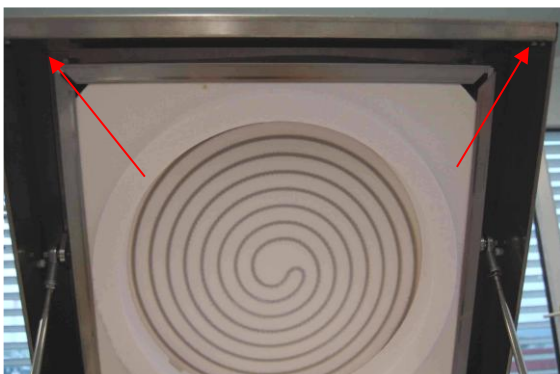

3. Close the cover via the touchscreen using .

4.  **Important:** Disconnect the prepASH from the mains. Pull the cover slightly forwards and then fold it back.

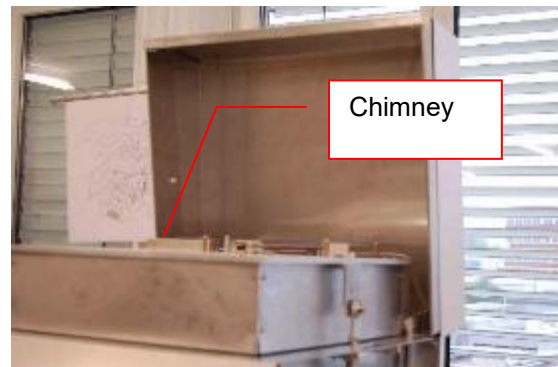

5. The chimney is now accessible.

13.3.1.3 Cleaning the chimney

1. Unscrew the angle plate and clean it mechanically.
2. If necessary, also clean the prepASH page.
3. The ceramic pipe may also be cleaned mechanically if it is dirty.



13.3.1.4 Fitting the hood

1. Fold the hood forward over the cover.
2.  Reconnect the prepASH to the mains and switch the device on.
3. Open the cover via the software.
4. Screw the hood back onto the cover (two bolts).
5. The device is now ready for operation.

14 Appendix A: Carbon application

This appendix only explains the differences between carbon and standard measurement. For general information on prepASH, please consult the actual manual.

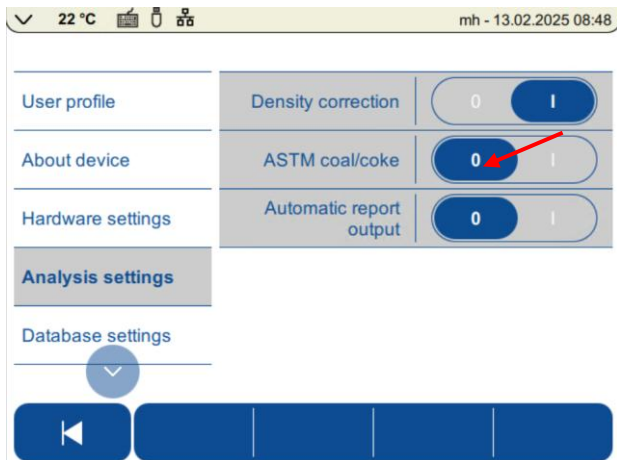

To be able to use the carbon application, this function must be activated in the "Analysis settings".

14.1 Method

In ASTM methods, the method steps for moisture, volatile components and ash are predefined. The duration, temperature, gas and autostop criterion can be changed, but not the step sequences. You can do without moisture, volatile components or the ash determination.

You are guided through the analysis via on-screen instructions. The volatile components require calibration.

ASTM methods are stored in a separate folder. As with the standard methods, you can either create a new method or edit an existing one. For general information on methods, see chapter 0 . If you edit an ASTM method, the calibration for volatile components of the original method is transferred to the new method. This is allowed as long as you do not change the parameters of the "Volatile components" step. To recalibrate the method, see 14.3 Calibration.

Create method

If you create a new method, it must be recalibrated. If you call up the method for the first time in an analysis, you will be prompted to perform a calibration. This first measurement is automatically performed as a calibration.



Edit method

If you edit a method, the calibration of the original method is adopted. This procedure is legitimate as long as the parameters of the steps of the volatile components are not changed.

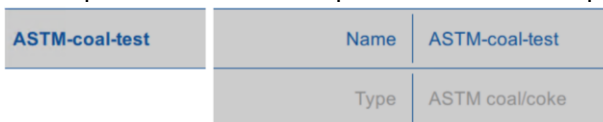

Work through all method steps both when creating and editing and changing the settings if necessary.



The method steps are predefined.

For the volatiles, the crucibles are covered with lids. Drying and ashing, on the other hand, is done with open crucibles.

Click on Steps and change the parameters according to your requirements

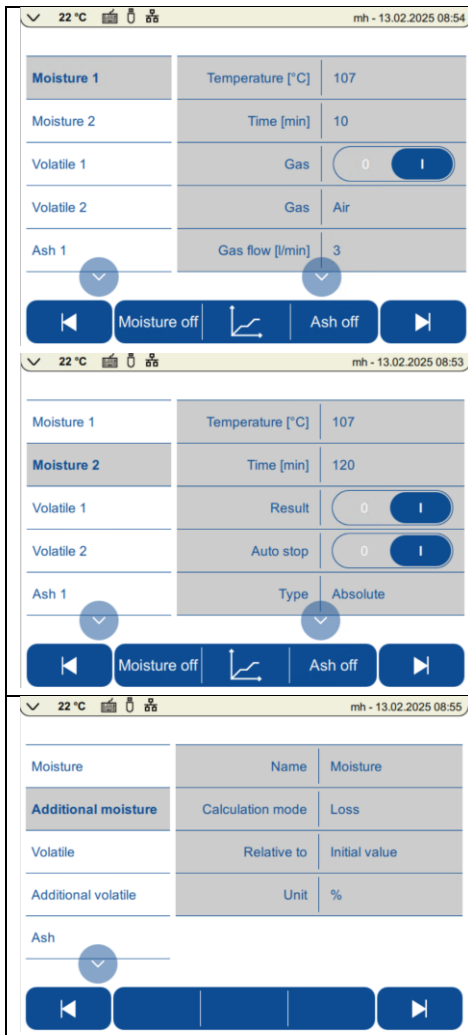

If you are working with dry samples, you can switch off the humidity; if ashing is not required, you can also switch off this step.

The step for the volatile components is special. According to the standard, measurements are not made for weight constancy, but for a defined time.

Measurement of the volatile components begins as soon as the temperature is only 2 % below the set target temperature (even if the ramp time selected is too short)

Select the calculations and the lid opening temperature.

14.2 Measurement

The procedure is the same as for standard methods. (6Program execution

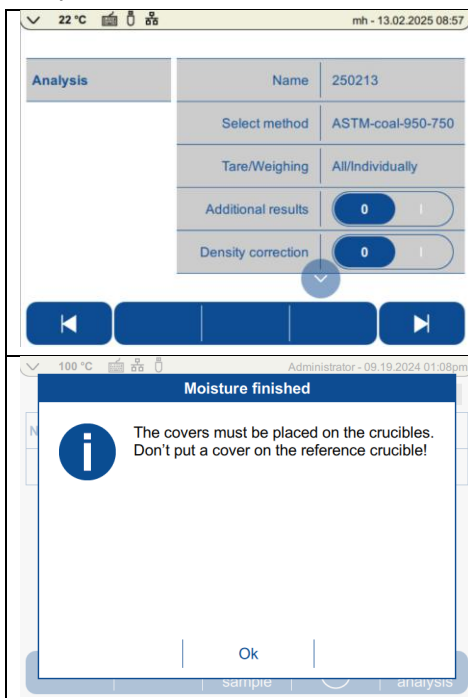

Enter the file name
 Select the method and the tare mode.
 Taring and weighing are carried out as with the standard method.

Start the run and follow the on-screen instructions.

After drying, the lid opens automatically (depending on the setting, the lid opening can also be triggered manually) and you must put lids on the crucibles. The reference crucible must not be covered!

After the lid opens for the second time, remove all crucible lids.



The prepASH can become very hot. Use the lid tongs when working.

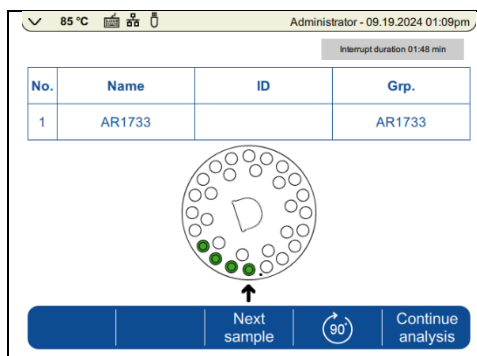

To make it easier to reach the crucibles, the sample tray can be rotated when the lid is open.

14.3 Calibration

As mentioned in chapter 14.1 Method, the carbon methods must be calibrated before use. You can perform a calibration with 1 to 29 reference samples (12 for model 212, 19 for model 219).

For a better result, we recommend taking more than one sample from each reference. Do not apply the repeat standards one after the other but distribute them to all positions (e.g. mirror-inverted for double determinations). Samples from the same group are averaged for the calibration. The calibration standards must therefore be assigned to a group. The easiest way to do this is to use the article or batch number.

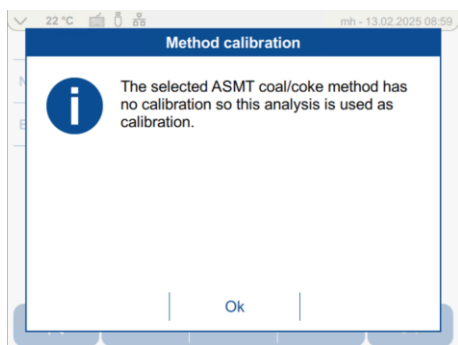

Confirm with OK. Carry out a measurement, regardless of which tare mode you are using. At the end of the analysis, assign the reference values to the measured values.

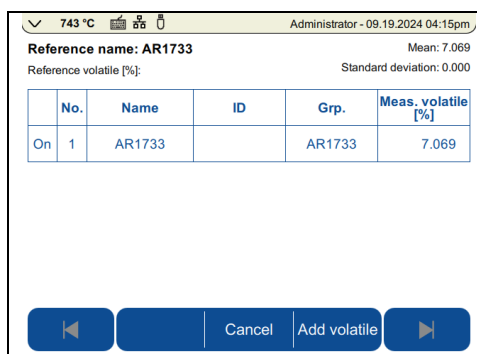

To do this, click on "Add Volatile"
Click on a line to remove the data set from the calibration or to add it again (ON/OFF)

CAUTION: Cancel (delete) leads to the entire calibration process being aborted.

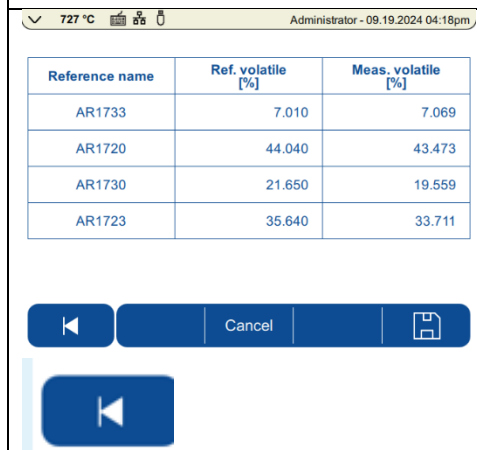

Once all reference values have been assigned, the mean values are calculated and the values of the calibration curve are displayed (the reference name is the group name of the sample list).

CAUTION: Cancel (delete) leads to the entire calibration process being aborted.

Here you can return to the reference value input list to add or remove data records or to correct input errors.



Save the calibration

14.3.1 Correction of volatile components

At the end of a carbon measurement, the volatile components are automatically adjusted.

Make sure that the calibration covers the entire range of expected volatile components. Values are calculated linearly between two calibration points.

14.4 Results

The results table is automatically adjusted for the carbon application. Moisture, volatile matter, ash and solid carbon are displayed. For more information on the calculations, see chapter 14.5.

Additional calculations can be defined in the method.

14.5 Calculations

14.5.1 Results

Designations for the calculation:

I = initial weight [g]

D = residue after the drying step = dry masses [g]

V = residue after volatile step [g]

A = residue after the ashing step [g]

C = Current measured value

Humidity [%] = $(I-D)/I \times 100\%$

Volatile matter [%] = $(V-D)/I \times 100$ related to initial weight

Volatile matter [%] = $(V-D)/D \times 100$ based on dry matter

Ash [%] = $A/I \times 100\%$ related to initial weight

Ash [%] = $A/D \times 100\%$ related to dry matter

Fixed carbon = $(V-A)/I \times 100\%$ related to initial weight

Fixed carbon = $(V-A)/D \times 100\%$ based on dry matter

15 Appendix B: Scrubber application/sulfated ash

This appendix only explains the differences between a normal measurement and a measurement with a scrubber connected. For general information on prepASH, please consult the actual manual.

For details on the operation and maintenance of the scrubber, please consult the scrubber manual. The scrubber allows exhaust fumes to be extracted directly from the furnace chamber and cleaned

Scrubber connection:

The scrubber is connected to the prepASH via the **condensation absorption connection set 340-9002**.

The condensation absorption connection set includes:

- Glass cooling coil
- High-temperature hose, 1m
- Power connection cable
- Flow termination, already installed in prepASH
- Centering connection for glass cooling coil, already installed in prepASH



Place the scrubber to the left of the prepASH or below the prepASH

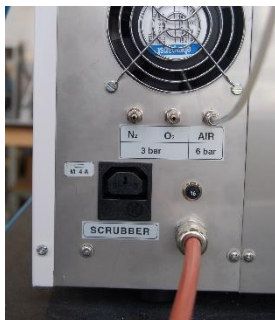

Connect the scrubber to the mains socket on the back of the prepASH. Use the special mains cable from the scrubber connection set 340-9002.



Quartz cooling coil:

ATTENTION: treat this sensitive quartz part with the necessary precaution.

Connect the high-temperature hose to the bottom of the quartz cooling coil.

Then carefully guide the lance of the cooling coil through the hole on the left side of the prepASH to the centering connection.

Connect the other side of the hose to the scrubber.

Do not forget to fill in the activated carbon and the washing liquid (scrubber manual).

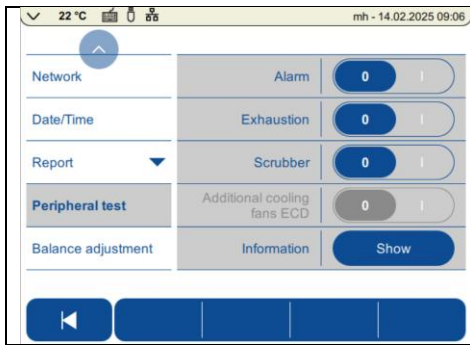

You can control and test the scrubber in the Periphery test (settings). If you set the controller to “on”, the pump should be audible and the wash water should bubble.

15.1 Scrubber operation

If the scrubber is connected to the mains socket on the back of the prepASH, it can be switched on and off via the prepASH.

You have the option of controlling the scrubber in each method step.

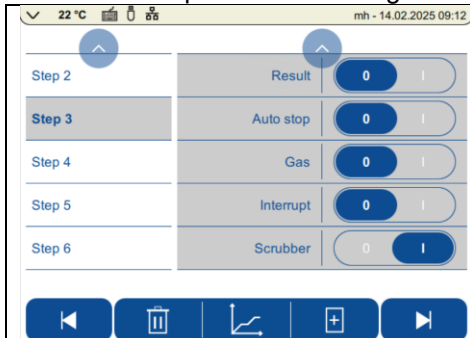

You have the option to control the scrubber in each method step. Set the switch to «on».

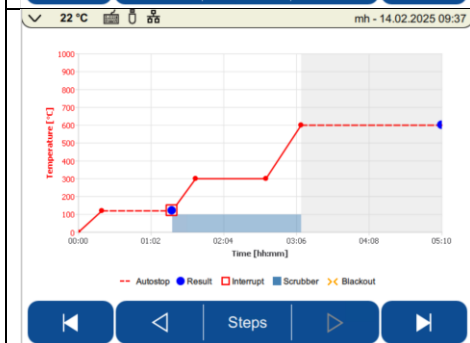

The use of the scrubber is necessary in all steps in which acid vapors are produced, namely when fuming off the sulfuric acid during the sulfated ash determination.

16 Appendix C: UPS/UPS power failure bridging

The uninterruptible power supply (UPS) prevents the loss of data in the event of a mains power failure and enables the analysis to continue automatically as soon as the mains power is restored. However, heating is not possible with the UPS, so the analysis is interrupted for the duration of the power failure. Thanks to good insulation, only low temperature losses are to be expected during short interruptions. The start and end of the interruption is shown in the graph in the log and the times are listed in a table. The temperature drop can also be seen in the log. If the autostop criterion is met, the data can normally be used. The operator is responsible for assessing and deciding whether a repetition is necessary.



Powerfail details:

Nr.	Start	Stop
1	0:21:49	0:38:23
2	1:12:10	1:59:37
3	2:42:34	3:06:14

17 Appendix D: Practical recommendations

17.1 Correct sample preparation

Prompt sample preparation prevents the exchange of moisture between the sample and the environment. If this is not possible, the samples should be stored temporarily in airtight containers until they are weighed.

Solids:

Distribute the powdered samples into the crucible. Solids and coarse samples should be crushed in a mortar or grinder. Avoid heating the sample so that it does not lose any moisture.

Liquids:

Pipette the samples directly into the crucibles. Make sure that no evaporation occurs before weighing.

17.2 Optimization of result accuracy and working with very low ash content

- Correct crucible handling is essential. See also chapter 17.3 Correct crucible handling and weighing
- Work with as large a sample quantity as possible. Please note that this will extend the measuring time and may impair homogeneous drying/incineration. See also large crucibles and adapters in chapter 18 Accessories and consumables.
- Use large pans to achieve faster and more homogeneous drying/incineration. See also large pans and adapters in the in chapter 18 Accessories and consumables.
- Please note that negative residual weights may occur sporadically with very low ash contents due to the reproducibility of the measuring system.

17.3 Correct crucible handling and weighing

- Only use one type of crucible per run and, if you are working with adapters, only one type of adapter. This means that all positions used, including the reference, must be fitted with the same type.
- Always work with clean and dry crucibles in order to obtain correct and reproducible results. Before each analysis, anneal the crucibles for at least 30 minutes at temperatures of 100 °C above the highest analysis temperature. This can be done in prepASH or in a muffle furnace. Store the crucibles in a desiccator filled with silica gel. Place the crucibles in the sample tray using tweezers or crucible tongs. Avoid touching the crucibles with your fingers. Also check that neither the bottom of the crucible nor the weighing pan are dirty.
- Carry out the weighing quickly to prevent moisture exchange with the environment.
- The weights of a group, which are statistically evaluated, should vary by a maximum of 10 %.
- Powdery samples and plastics tend to become electrostatically charged, which greatly affects the performance of the built-in analytical balance. Discharge the sample with an ionizing device.

17.4 Adaptation of the existing test procedure

The moisture and ash analyzer is often used instead of other drying and ashing techniques. (such as drying furnaces and muffle furnaces), as prepASH is easier to operate and saves time. The method parameters must be selected in prepASH in such a way that comparable results are achieved.

- Carry out parallel measurements
- Vary the endpoint criteria
- Adjust the sample weight (the lower, the faster, the higher, the more accurate)
- Work with calibration curves (e.g. ASTM coal and coke)

17.5 Possible causes and correction of incorrect results

The weight display is not constant

- Excessive air flows at the installation site of the appliance
- The base vibrates or is not stable
- The weighing pan touches a foreign object (check the position of the sample tray)

- The sample absorbs moisture
 - The sample loses moisture
 - Sample does not have the same temperature as the environment
- Results are clearly wrong
- Crucibles were not cleaned or annealed correctly
 - The device has not been correctly tared.
 - The calibration is no longer correct

18 Accessories and consumables

18.1 Accessories

3-fold process gas unit for air and 2 other gases: 340-8502

Built-in process gas flow unit for air and 2 other gases such as N₂ and O₂



ECD: Enhanced Cooling Device

Built-in cooling system for rapid cooling between runs

340-8504: Factory-fitted cooling system for rapid cooling between the barrels

350-9004: Conversion kit (only prepASH devices after November 2013)



Sample tray holder: 340-8012

Helpful when handling hot sample trays outside the prepASH, e.g. when adding sulfuric acid under a fume cupboard during sulfated ash determination



Condensation absorption unit (scrubber): 340-9001

For pre-incineration in sulfated ash determination Triple Scrub (No. 114152330) consisting of a neutralization stage, an absorption stage, a cold trap and a collection vessel.



Condensation-absorption connection set: 340-9002

Connects the scrubber to the prepASH

18.2 Consumables

Sample tray for 29/19 samples, SiC, silicate Ceramic: **340-4065**



Sample tray for 12 samples, SiC, silicate Ceramic: **340-4072**



Set of 5 crucibles (porcelain glazed), 25 ml:
for sample tray 29/19 340-4065
Suitable for use with acids



Set of 5 crucibles for use with lids (Al₂O₃), 26ml: **340-8032**
for sample tray 29/19 340-4065 and crucible lid 340-8033



Set of 5 crucible lids, (Al₂O₃): **340-8033**
for sample tray 29/19 340-4065 and crucible 340-8032



Set of 5 adapters, (SiC, silicate ceramic): **340-8035**
only for sample tray 12 340-4072 and standard crucible 340-8034 or freely available crucibles (diameter: bottom < 32 mm, top < 55 mm)



Set of 5 crucibles, (SiC, ASTM-D-189-65), 40 ml: **340-8034**
only for sample tray 12 340-4072 together with adapters 340-8035
Suitable for use with acids



Set of 5 crucibles, (porcelain glazed), 50 ml: **340-8038**
only for sample tray 12 340-4072 together with adapters 340-8035
Suitable for use with acids



19 Technical data

Model	prepASH 229	prepASH 219	prepASH 212
Number of samples, crucible			
Number of samples	29	19	12
Sample tray for 19/29 samples	Standard	Standard	no
Crucible 25 ml	35	25	no
Sample tray for 12 samples	Option	Option	Standard
Adapter	Option	Option	15
Crucible 40 ml	Option	Option	15
Crucible 50 ml	Option	Option	Option
Weighing system			
Weighing range	120 g	120 g	120 g
Readability	0.0001 g	0.0001 g	0.0001 g
Minimum sample weight	0.1 g	0.1 g	0.1 g
Heating system			
Temperature range	50 °C - 1000 °C	50 °C - 1000 °C	50 °C - 1000 °C
Temperature stability	+/- 2 %	+/- 2 %	+/- 2 %
Sequence control			
Maximum program steps	15	15	15
Maximum total analysis time	50 h	50 h	50 h
Auto stop	0.1 - 120'000 mg / 5-200 min) or (0.1-100 %/5-200 min).	0.1 - 120'000 mg / 5-200 min) or (0.1-100 %/5-200 min).	0.1 - 120'000 mg / 5-200 min) or (0.1-100 %/5-200 min).
Atmosphere			
Oxygen, 0/3/6/9 l/min	Option	Option	Option
Nitrogen, 0/3/6/9 l/min	Option	Option	Option
Compressed air, 0/3/6/9 l/min	Option	Option	Option
Suction system	Yes	Yes	Yes
Extraction device for sulfate ash	Option	Option	Option
Results			
Weight loss/residual weight	%, ‰, g	%, ‰, g	%, ‰, g
Weight loss/residual weight relative to previous interval	%, ‰, g	%, ‰, g	%, ‰, g
Repeatability	1 g / 0.02 %	1 g / 0.02 %	1 g / 0.02 %
Monitoring			
Remote to PC via network	Yes	Yes	Yes
Acoustic	Yes	Yes	Yes
Operation			
Screen	5.7" VGA color	5.7" VGA color	5.7" VGA color
Keyboard	touch screen	touch screen	touch screen
Menu-driven	Yes	Yes	Yes
PC independent operation	Yes	Yes	Yes
Sample tables, preparation and evaluation on PC via network	Yes	Yes	Yes
Sample preparation outside (with balance)	Yes	Yes	Yes
Expression			
Graphic	Yes	Yes	Yes
Table	Yes	Yes	Yes
Methods	Yes	Yes	Yes

Model	prepASH 229	prepASH 219	prepASH 212
Ccapacity			
Methods	unlimited	unlimited	unlimited
Measurement data	unlimited	unlimited	unlimited
Data outputs, interface			
RS232 interface for external weighing	with USB converter	with USB converter	with USB converter
USB for printer	Yes	Yes	Yes
USB for barcode scanner	Yes	Yes	Yes
USB for memory stick	Yes	Yes	Yes
USB for external weighing	Yes	Yes	Yes
Ethernet for printers	Yes	Yes	Yes
Ethernet for PC data evaluation	Yes	Yes	Yes
Ethernet for remote PC monitoring	Yes	Yes	Yes
Ethernet for remote PC support	Yes	Yes	Yes
Calibration			
Balance	2 point	2 point	2 point
Temperature	2 point	2 point	2 point
Connection			
Mains voltage	230 VAC (+15/-20 %)	230 VAC (+15/-20 %)	230 VAC (+15/-20 %)
Frequency	50 to 60 Hz	50 to 60 Hz	50 to 60 Hz
Power consumption	15 A	15 A	15 A
Weight and dimensions			
Weight	99 kg	99 kg	99 kg
Dimensions (H) Height with lid open	H (H) x W x D / 620 (980) x 590 x 870 mm	H (H) x W x D / 620 (980) x 590 x 870 mm	H (H) x W x D / 620 (980) x 590 x 870 mm