

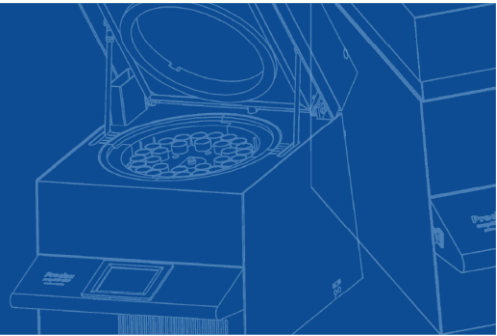

prepASH



prepASH 2xx Pre installation instruction

Please refer to manuals for full information



1. Requirements for installation of prepASH 2xx

- **Mains connection**
 - Voltage: 230 VAC (+15/-20 %), for 110V mains connection use two phases
 - Current: 25A
 - Frequency: 50 to 60 Hz
 - Connector: CEE type, 3 pole, 25 A, male, only N (blue), L1 (brown) and PE (yellow green) connected
- **Permissible ambient conditions**
 - Temperature: 5 °C – 35 °C
 - Relative humidity: 25 % - 85 %, not condensing
- **Weight and dimensions**
 - Weight 99 kg
 - Dimension H(H) x W x D / 620(980) x 590 x 830 mm
(H) Height with sample chamber open
- **Requisite footprint**
 - W x D / 590 x 830 mm (Requires a margin of 15 cm for security)

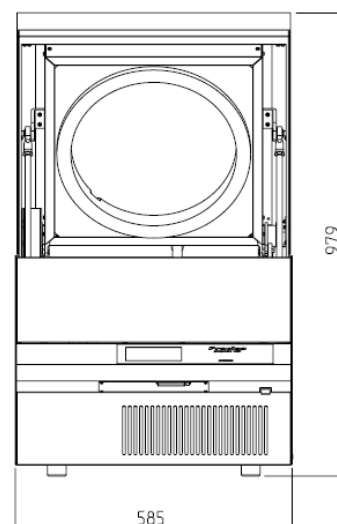
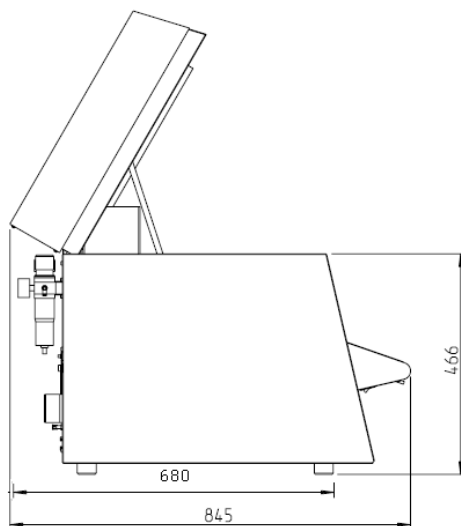

- **Gas requirements**

- Compressed air:

- 6 bar ($\pm 10\%$), with air turnover of 2-3 l/min

- Compressed air oil-free and without condensation. (ISO 8573-1:2010, at least standard 7.4.4 (solid particles 5-10 mg/m³; water: vapor pressure dew point $< + 3\text{ }^{\circ}\text{C}$, water liquid -; oil 5 mg/m³)

- Set 6bar at the maintenance unit of the prepASH. Note: 4bar is the absolute minimum to lift the hood!
The compressed air inlet (AIR) is connected to the maintenance unit in the factory.

- Tubing for compressed air with an inner/outer diameter of 6/8 mm or replace with any 1/8" connection (NOT INCLUDED IN DELIVERY).**

- Optional working with Oxygen:

- Oxygen 99.5 % purity, 3 bar ($\pm 10\%$), 0 – 9 l/min

- The process gases can be fed in via the terminal connections (10) with hoses (outer \varnothing x thickness 4 x 0.75mm).

- Tubing for process gases (NOT INCLUDED IN DELIVERY).**

- Optional working with Nitrogen:

- Nitrogen 99.5 % purity, 3 bar ($\pm 10\%$), 0 – 9l/min

- The process gases can be fed in via the terminal connections (10) with hoses (outer \varnothing x thickness 4 x 0.75mm).

- Tubing for process gases (NOT INCLUDED IN DELIVERY).**

- **Exhaust gas hose (included in delivery)**

- Diameter inner/outer 63/68 mm, length 2 m, flow about 40m³/h, Temperature about 50°C
exhaust gases must be removed from the working room (hood)

- Installation not needed at exhibition and demonstration without sample running

2. prepDATA PC requirements

- **PC or Laptop requirements**
 - Windows XP / 7 / 8 / 10
 - Windows Office
 - USB Host (for balance connection)

3. Option Scrubber, (Büchi K-415, 340-9001 see details in manual of Scrubber)

- **Space required**
 - Dimension (W x H x D) 347 x 417 x 526 mm
 - place scrubber on the left-hand side of prepASH or under the prepASH
 - space required for the connection set on the left-hand side of prepASH (between scrubber and prepASH) approx. 100 mm
- **Mains connection**
 - No, the scrubber is fed by prepASH
- **Others**
 - Cooling water, tubing silicon 6/9
- **Chemicals**
 - Wash solution: Na₂CO₃ or NaOH
 - Bromothymol blue as indicator
 - Optional active carbon: granulated, size: 2-6 mm

4. Option prepSTATION, (see details in prepSTATION)

- **Space required**

- prepSTATION BxD 300 x 350 mm
- Balance 250 x 400 mm plus on each side 150 to 200 mm space
- Recommended space for easy work: 900 mm plus space for PC / Laptop

- **PC or Laptop requirements**

- Windows XP / 7 / 8 / 10
- Windows Office
- USB Host (for connection to the balance)
- Network (LAN) access or direct connection to prepASH via Ethernet cable. **Ethernet cable is NOT included in the delivery.**
- VCP driver from FTDI (VCP stands for Virtual COM Port) for the connection to the balance. The driver is available on the USB stick (or homepage from FTDI). Someone with IT administrator rights must be on place at time of installation. The PC must be part of the same subnet as the prepASH.

- **Mains connection**

- For balance (power adapter included) the prepSTATION is fed by balance
- For PC / Laptop

5 Installation

5.1 Installation

Observe the following points when you unpack the ashing device in order to avoid damage:

- Check the ashing device for any external visible signs of damage immediately after you unpack it. If you find that it has been damaged in transit, notify your Precisa service agent immediately.
- Read these Operating Instructions carefully before starting to work with the ashing device and pay particular attention to the safety instructions

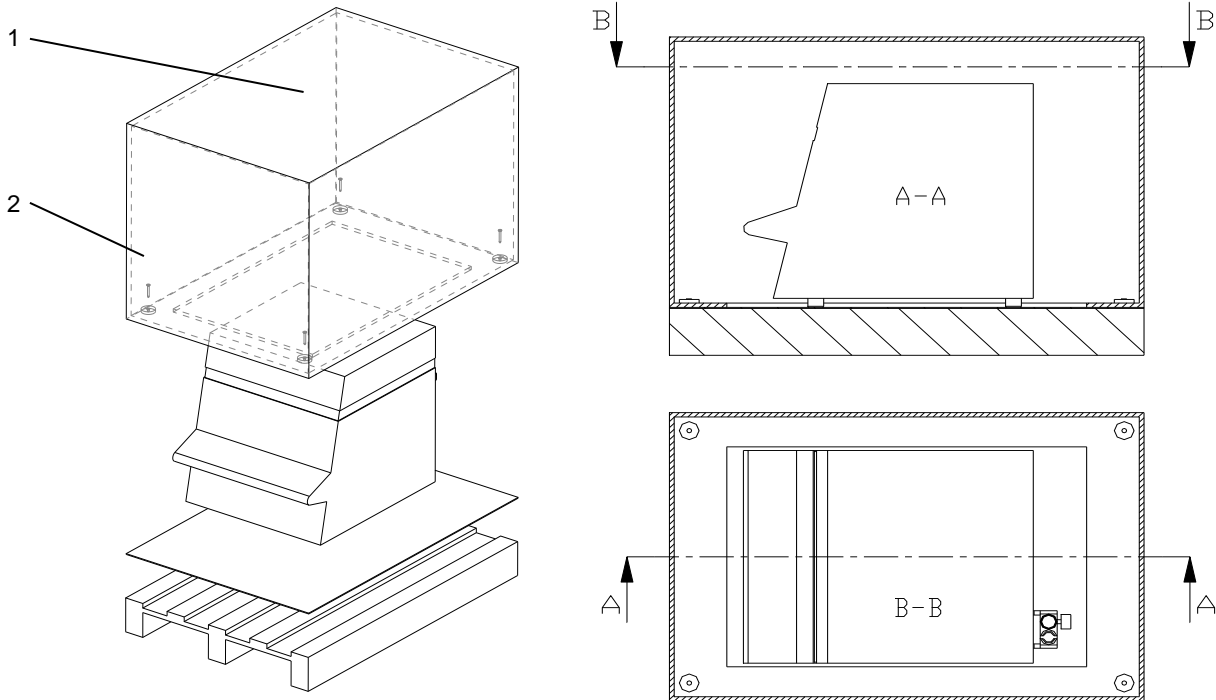

Unpacking the prepASH

1. Open the box (1) at the top
2. Remove all the padding and accessories
3. Undo the 4 screws (2) on the base of the cardboard box
4. Lift off the cardboard box

NOTE

Retain the packaging. If the device is delivered to the factory by a transport firm for repair after a lengthy period of use, this may only be done in the original packaging. If devices are not properly packaged, they may sustain considerable damage in transit.

5.2 Assembly and Connection

NOTE

All the parts must be attached without exerting undue force. Do not apply any undue force. If you have any problems, the Precisa customer service representative will be happy to assist.

The ashing device does not come fully assembled. Carry out the steps in the sequence outlined below:

1. Arrange to have an electrician assemble the plug:
 - L →Phase 230 VAC
 - E →Earth
 - N →Neutral
2. Remove the protective stoppers from the requisite connections (process gases and waste gas nozzle) on the back of the device.
3. Attach the compressed air, the process gases, the mains cable, the waste gas hose and, if necessary, the alarm plug to the designated connection points
4. Regulate the pressure of the compressed air supply using the attached maintenance

DANGER

The ashing device is operated with a 230 V AC supply. The electrical wiring work should be carried out by a qualified electrician.

Have the electrician check that existing electrical installations are in good working order and that fuses and cable cross sections are sufficient for the connection data on the rating plate for the ashing device.

The exhaust gas hose must be fed into an exhaust system in order to discharge harmful waste gases from the furnace chamber safely.

5.2.1 Structure of the Ashing Device

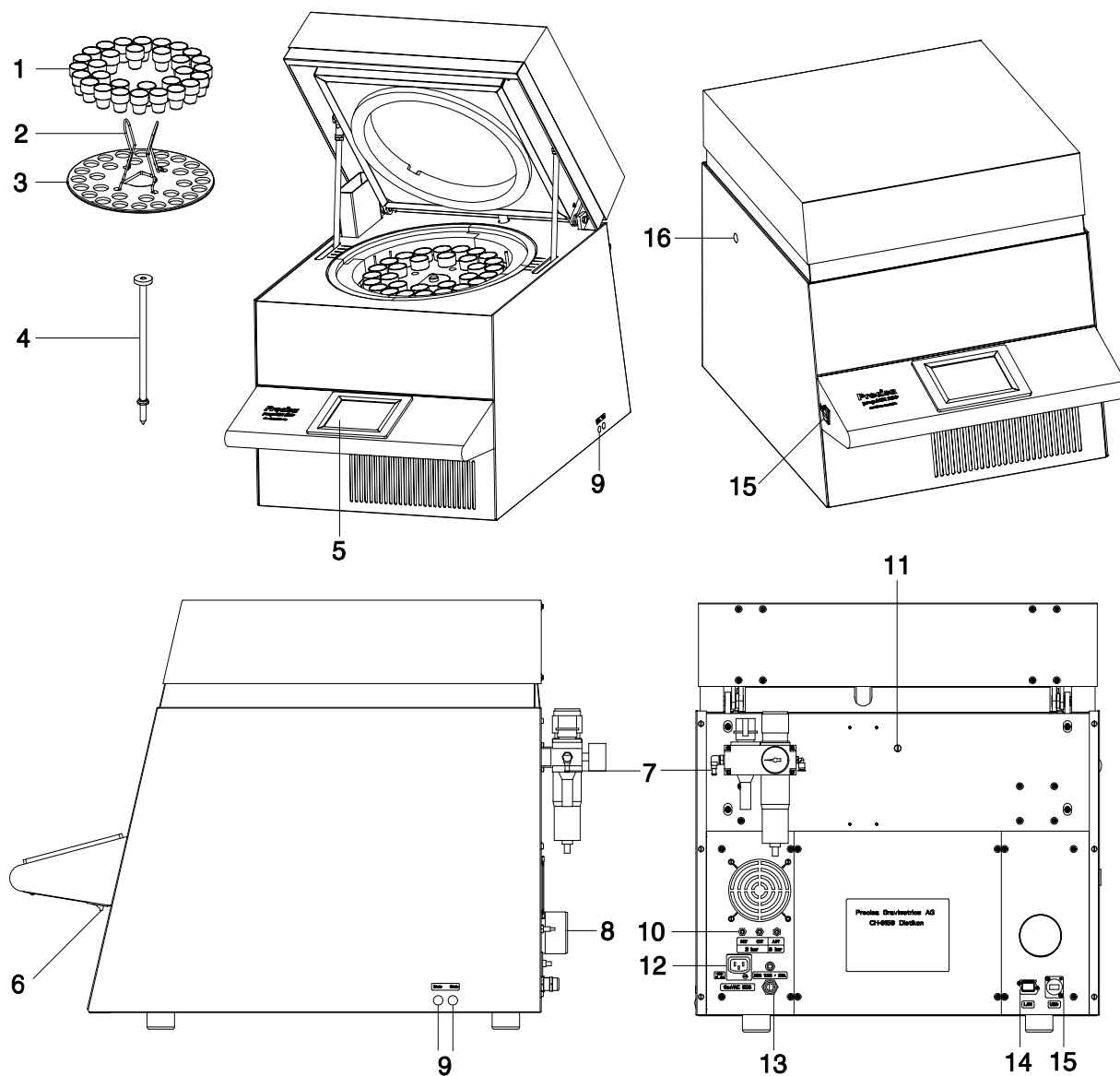

- | | | | |
|---|---|----|---|
| 1 | Crucible | 9 | Process gas flow control |
| 2 | Plate holder | 10 | Process gas and compressed air connections |
| 3 | Turn table | 11 | Inlet for temperature sensor |
| 4 | Balance pan | 12 | Electrical connection for scrubber |
| 5 | Touch screen | 13 | Mains connection cable with connector CEEtyp 5pole male |
| 6 | Master switch | 14 | LAN Port |
| 7 | Maintenance unit with a compressed air connection | 15 | USB Port |
| 8 | Exhaust gas nozzle | 16 | Mechanical connection for scrubber |