

# ***Precisa***

■ The Balance of Quality ■

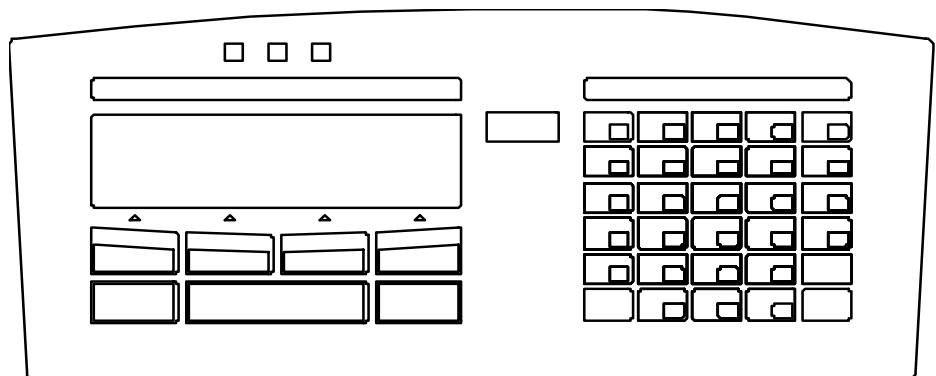
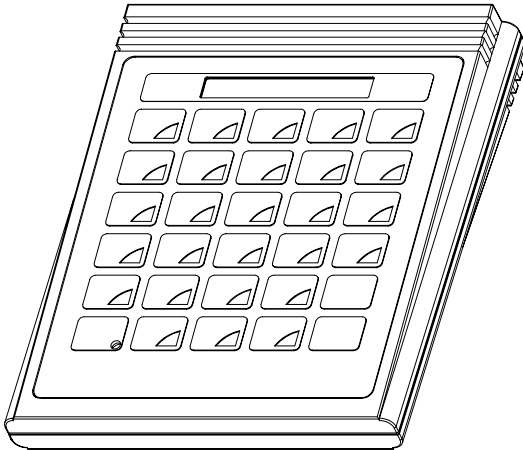

**Operating Instructions  
Smartbox**

**Finished pack control**

<b>1</b>	<b>Brief description</b>	<b>5</b>
1.1	Starting up	5
1.1.1	Smartbox type: External box	5
1.1.2	Smartbox type: In balance-terminal integrated	5
<b>2</b>	<b>Description of keys</b>	<b>6</b>
<b>3</b>	<b>Configuration menu</b>	<b>7</b>
3.1	Printing out the configuration	9
3.2	Arrangement of output channels	10
3.3	Operating diagram for signallamp (TU,TO)	10
3.4	Connection of external keys	11
3.5	Conformity with FPVO	11
<b>4</b>	<b>Menu</b>	<b>12</b>
<b>5</b>	<b>Error messages</b>	<b>12</b>
<b>6</b>	<b>General notes</b>	<b>13</b>
6.1	General settings	13
6.2	Program update	13
6.3	Technical data	13
<b>7</b>	<b>Article</b>	<b>14</b>
7.1	The components of the article	14
7.2	The signallamp limits of the article	15
7.3	Storing an article	16
7.4	Editing an article	17
7.5	Loading an article from the memory	18
7.6	Deleting an article from the article memory	18
7.7	Deleting all articles from the memory	18
7.8	Deleting the article from the working memory	18
7.9	Barcodes and articles	19
7.10	Table for automatic tolerance calculation (TU1, TU2)	19
<b>8</b>	<b>Tare</b>	<b>20</b>
8.1	Storing a tare in the tare memory	20
8.2	Deleting the current tare	20
8.3	Loading a tare from the tare memory	20
8.4	Deleting a tare from the tare memory	21
8.5	Deleting all tares from the tare memory	21
8.6	Pre-setting tare using the decimal keypad	21
8.7	Barcode and tare	21

<b>9</b>	<b>Printout</b>	<b>22</b>
9.1	Printing out measurements	22
9.2	Allocating a fixed print format to the PRINT key	22
9.3	Printing out an article	22
9.4	Printing out a list of articles	22
9.5	Printing out a tare from the tare memory	23
9.6	Printing out the list of tares	23
9.7	Printing out the current tare	23
9.8	Printing out the current density	23
9.9	Printing out the version of the Smartbox software	23
<b>10</b>	<b>Finished pack checking with mean tare</b>	<b>24</b>
10.1	Finished pack checking with temporary article memory	24
10.2	FPVO statistics printout with mean tare	25
<b>11</b>	<b>Finished pack check with individual (prior) tare</b>	<b>26</b>
11.1	Finished pack check using article memory	26
11.2	FPVO statistics printout with prior individual tare	28
<b>12</b>	<b>Finished pack check with individual (subsequent) tare</b>	<b>29</b>
12.1	Finished pack check using article memory	29
12.2	FPVO statistics printout with subsequent individual tare	31
<b>13</b>	<b>Mean tare determination</b>	<b>32</b>
13.1	Mean tare determination with temporary article memory	32
13.2	Statistics printout of the mean tare	33
<b>14</b>	<b>Daily and weekly statistics (STAT 1 and STAT 2)</b>	<b>34</b>
14.1	Daily statistics printout (STAT 1)	34
14.2	Weekly statistics printout (STAT 2)	35
14.3	Deleting statistics	35
<b>15</b>	<b>Defining print formats</b>	<b>36</b>
15.1	Storing an ASCII text line	36
15.2	Storing a line of HEX (control codes)	36
15.3	Deleting a text or HEX line	36
15.4	Pre-defined text lines	37
15.5	Storing a print format	39
15.6	Allocate print format to the PRINT key	39

<b>16</b>	<b>Eltron LP2022SE or LP2824 Barcode-Printer</b>	<b>40</b>
16.1	Print article number in EAN8 code (Printformat 16)	40
16.2	Print article number in EAN13 code (Printformat 17)	40
16.3	Print article number in Code39 (Printformat 18)	40
16.4	Print tare weight in EAN13 code (Printformat 19)	40
16.5	Print reference density in EAN13 code (Printformat 20)	40
16.6	Print text-label (Printformat 21)	40
<b>17</b>	<b>Barcode-Reader</b>	<b>41</b>
17.1	Storing an article number with the barcode-reader	41
17.2	Loading an article with the barcode-reader	41
17.3	Reading in a reference density with the barcode-reader	41
17.4	Reading in tare weight with the barcode-reader	41
<b>18</b>	<b>Reference-Balance</b>	<b>42</b>
18.1	Configuring the reference-balance	42
18.2	Transferring tare weight	42
<b>19</b>	<b>Interfaces and accessories</b>	<b>43</b>
19.1	Standard interface	43
<b>20</b>	<b>Controlling the Smartbox remotely via the interface</b>	<b>44</b>
20.1	Key code for the functions	44
20.2	Direct commands	45
20.2.1	Direct commands for the article	45
20.2.2	Direct commands for the tare	46
20.2.3	Direct commands for the strings and print formats	47
<b>21</b>	<b>Tips and tricks</b>	<b>48</b>
21.1	< DISP > key	48
21.2	< ↺ > key	48
21.3	< - > key	48

## 1 Brief description

The SMARTBOX FPVO program provides a number of ways of determining the fill quantity of individual product ranges in accordance with the Finished Pack Regulations.

You can store article numbers, product names, reference densities and tare weights in the permanent memory and activate them as required.

### 1.1 Starting up

#### 1.1.1 Smartbox type: External box

Please connect the RS232-interface of the balance with one of the two BUS-connectors of the Smartbox by using the included datacable. While the Smartbox is connected to the balance, CH1 of the Smartbox takes over the functions of the RS232-interface of the balance.

The second bus-connector serves as a connector for further peripheral devices.

#### 1.1.2 Smartbox type: In balance-terminal integrated

Press the MENU/ESC key on the left side of the terminal and select the application "SMARTBOX".

## **2 Description of keys**

< ENTER >	Confirmation key
< CLR >	Delete key
< SHIFT >	Select alphabetical characters
< - >	Change sign or switch over to difference display if nominal value available.
< PRINT >	Enable data transfer
< STAT1 >	Info on Statistic 1
< STAT2 >	Info on Statistic 2
< → T >	Tare input
< ART >	Store or recall an article
< STO >	Store ( tare, article, etc.)
< RCL >	Recall ( tare, article, etc.)
< MEM >	Store a measurement
< INFO >	Display or print various values
< BASE >	Switch to "data-input from channel (ref. balance)". Instead of data-input via keyboard, "data-input from channel" may be selected by using <BASE > "No. " < ENTER >.
< DISP >	Switch between capacity display and text display
< ↻ >	Change unit (weight, density, percent)
< MENU >	Menu key
< CONF >	Configuration key
< DENS. >	Reference density key
< . >	Decimal point
< 8 >	Figure
<SHIFT> < M >	Letter (hold alpha key = change between capital- and small-letter)

### 3 Configuration menu

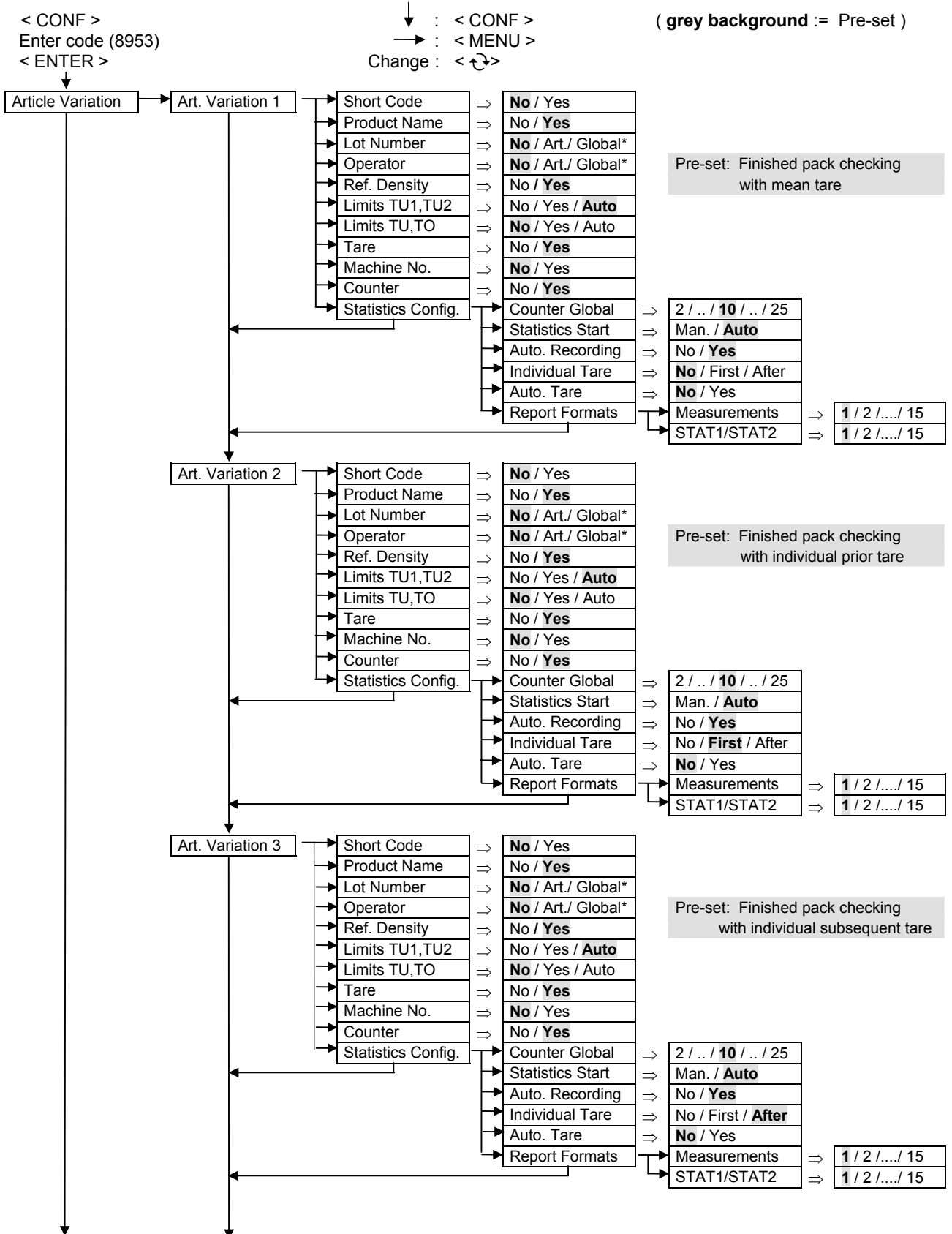

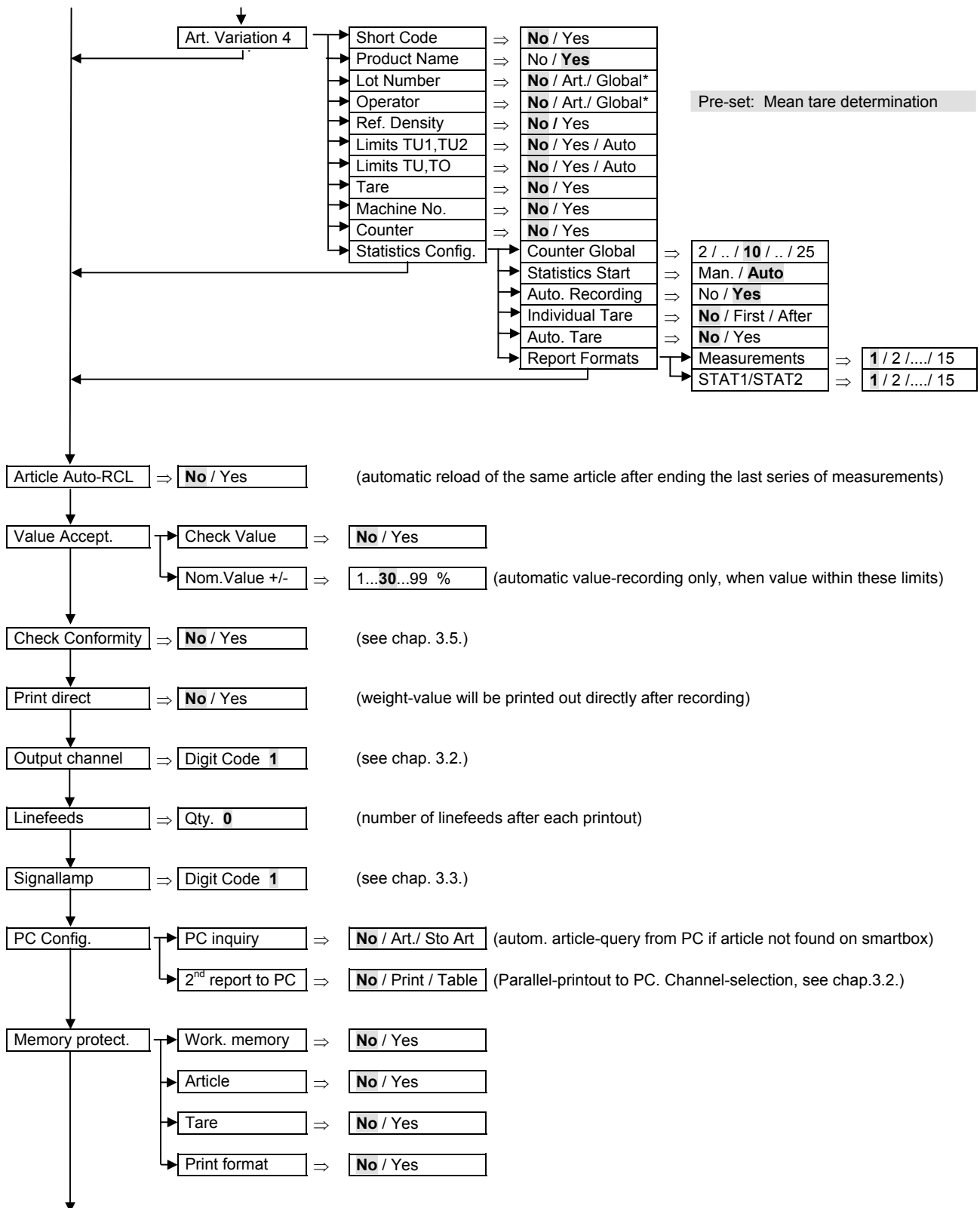

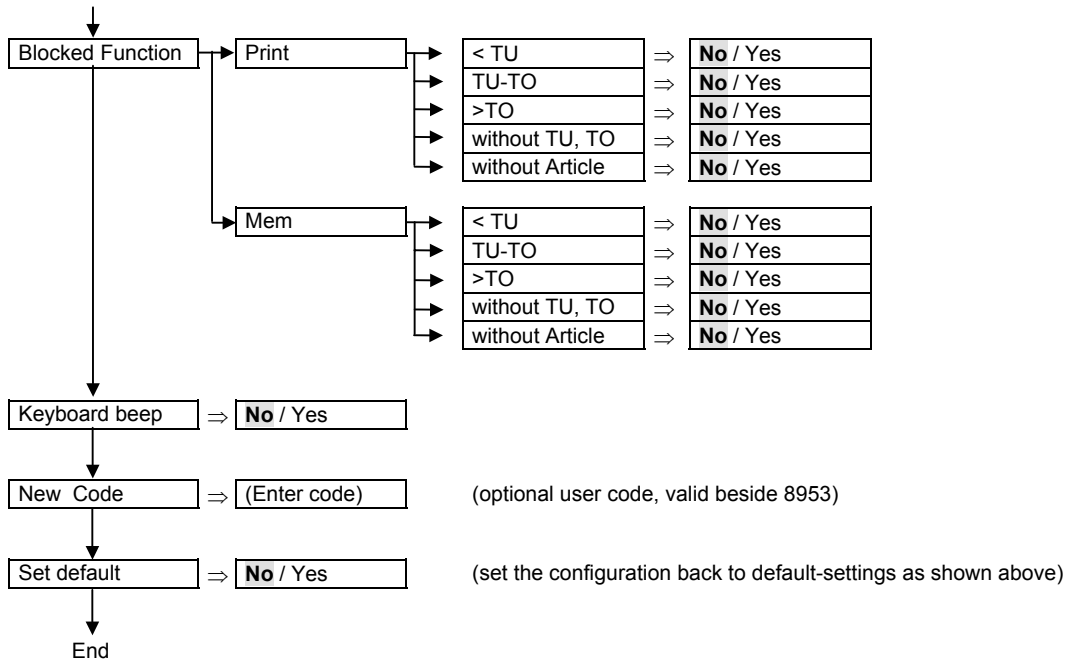

Notes:

\* Lot number, Operator: *Article* = defined in each article  
*Global* = defined globally. To be entered when loading an article.

### 3.1 Printing out the configuration

< INFO >  
 < PRINT >  
 < CONF >

### 3.2 Arrangement of output channels

In the case of the output channels a predetermined model 1..6 or a user model (always 6 digits) may be entered.

Predetermined Model	On Smartbox (addr=0)	On Smartbox (addr=1)	External: (addr 2...15) lowest address	External: (addr 2...15)	External: (addr 2...15)	External: (addr 2...15) highest address
	Chn. 1	Chn. 2	Chn. 3	Chn. 4	Chn. 5	Chn. 6
1 default	1	2	0	0	0	0
2	1	3	0	0	0	0
3	1	2	3	0	0	0
4	1	2	3	4	0	0
5	1	2	3	4	5	0
6	1	5	0	0	0	0

Function
0 = No Function
1 = Report printer (standard-printout)
2 = Barcode reader
3 = Reference balance (base)
4 = Barcode printer
5 = PC connection (2 <sup>nd</sup> report)
6-8 = External keys (see chap. 3.4.)

Exp.1: Printer connected to channel 1, barcode-reader connected to channel 2

Configuration-menu: „Output Ch. 1“ or „Output Ch. 1 2 0 0 0 0“

Exp.2: Printer connected to channel 1, reference-balance connected to channel 2, barcode-printer connected to channel 3

Configuration-menu: „Output Ch. 1 3 4 0 0 0“

### 3.3 Operating diagram for signallamp (TU,TO)

Model	Red light $\ominus$	Buzzer (stable)	Green light $\times$	Buzzer (stable)	Yellow light $\oplus$	Buzzer (stable)
1 default	50% - TU (always)	-	TU - TO (always)	-	TO - OL (always)	-
2	0% - TU (always)	-	TU - TO (always)	-	TO - OL (always)	-
3	50% - TU (stable)	-	TU - TO (stable)	-	TO - OL (stable)	-
4	0% - TU (stable)	-	TU - TO (stable)	-	TO - OL (stable)	-
5	50% - TU (always)	Beep	TU - TO (always)	-	TO - OL (always)	-
6	0% - TU (always)	Beep	TU - TO (always)	-	TO - OL (always)	-
7	50% - TU (stable)	Beep	TU - TO (stable)	-	TO - OL (stable)	-
8	0% - TU (stable)	Beep	TU - TO (stable)	-	TO - OL (stable)	-
9	50% - TU (always)	-	TU - TO (always)	Beep	TO - OL (always)	-
10	0% - TU (always)	-	TU - TO (always)	Beep	TO - OL (always)	-
11	50% - TU (stable)	-	TU - TO (stable)	Beep	TO - OL (stable)	-
12	0% - TU (stable)	-	TU - TO (stable)	Beep	TO - OL (stable)	-
13	50% - TU (always)	-	TU - TO (always)	-	TO - OL (always)	Beep
14	0% - TU (always)	-	TU - TO (always)	-	TO - OL (always)	Beep
15	50% - TU (stable)	-	TU - TO (stable)	-	TO - OL (stable)	Beep
16	0% - TU (stable)	-	TU - TO (stable)	-	TO - OL (stable)	Beep
17	50% - TU (always)	Beep	TU - TO (always)	-	TO - OL (always)	Beep
18	0% - TU (always)	Beep	TU - TO (always)	-	TO - OL (always)	Beep
19	50% - TU (stable)	Beep	TU - TO (stable)	-	TO - OL (stable)	Beep
20	0% - TU (stable)	Beep	TU - TO (stable)	-	TO - OL (stable)	Beep

Exp.: Red = from 50% of the nominal value to TU always light  
 Green = from TU to TO always light; short acoustic signal, as soon as weight is stable  
 Yellow = from TO to OL (Overload) always light

Configuration-menu: „Signallamp 9“

### 3.4 Connection of external keys

At pins DTR and CTS or RS232-Out and RS232-In of a channel of your choice an external key can be connected to.

By short-circuiting briefly these two pins (e.g. DTR and CTS) a tare-, print- or mem-command can be initiated.

Please note: Only channel 1 and channel 2 are available for this function.

Function	Pin DTR and CTS	Pin RS232-Out and RS232-In
6	Tare - Key	Print - Key
7	Tare - Key	Mem - Key
8	Print - Key	Mem - Key

Exp.: Printer connected to channel 1, external tare-key connected to pin DTR and CTS of channel 2.

Configuration-menu: „Output Ch. **1 6 0 0 0 0**“

### 3.5 Conformity with FPVO

- A sample passes the conformity-test if the series of measurement fulfills the following conditions:
  - None of the values under the TU2-Limit
  - Max. 2.0% of the values under the TU1-Limit
  - Mean-value must be greater or equal Nominal-value
  
- The test-result (“conformal” or “not conformal”) will appear in the FPVO-statistics printout.

### 4 Menu

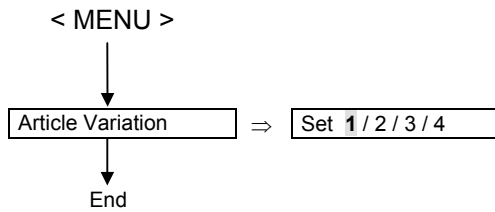

The selection of the variation number (1...4) defines which values will be prompted during the storage of an article (see chapter 3 “article variation”).

### 5 Error messages

Display:	aa ErrXX .....	(aa: Device-address)
Exp.:	72 Err40 ARTICLE NOT FOUND	(72: Device-address of Smartbox)

'Statistic-data exist'	Err36
'Statistic is running'	Err37
'Memory protected'	Err38
'Article not found'	Err40
'Not enough memory'	Err44
'Tare-No. too big'	Err46

### 6 General notes

#### 6.1 General settings

Language settings (German, English and French) and interface parameters (RS232) are taken from the balance-configuration and can only be set there.

#### 6.2 Program update

The program can be loaded into the Smartbox using a special PC-download-software. For downloading, COM x of the PC and Ch.1 of the Smartbox must be used.

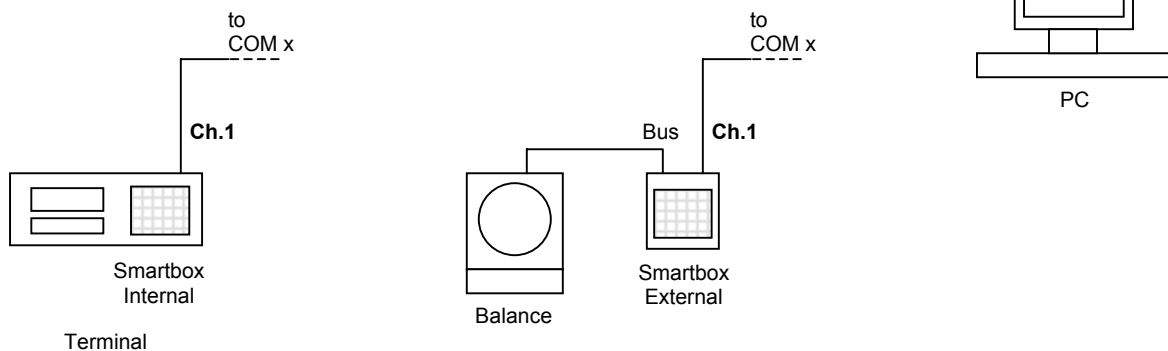

#### 6.3 Technical data

Maximal memory capacity :

500	Articles with daily and weekly statistics
250	Tares

## 7 Article

### 7.1 The components of the article

Name	Input requirements	Format	Description
Article number	ART. NO. ?	20 characters	Identification of the article An article can be activated or deleted using its identification
Article variation	ART. VARIATION x	1..4	Current article variation can be changed here
Short code	SHORT CODE ?	3 characters	Short identification of the article for activation
Product name	PROD ?	20 characters	Description of the article
Lot No.	LOT NO. ?	20 characters	Lot number for information
Operator	OPERATOR ?	20 characters	Operator name for information
Ref. Density	DENSITY g/ml ?	Real number	Reference density
Nominal value	NOM. VALUE g ?	Real number	Nominal value for statistics and tolerances in the reference unit or base unit
First lower limit	TU1 g ?	Real number	First lower limit for the statistics in the reference unit or base unit
Second lower limit	TU2 g ?	Real number	Second lower limit for statistics in the reference unit or base unit
Lower limit	TU g ?	Real number	Lower limit for plus/minus display and statistics in the reference unit or base unit
Upper limit	TO g ?	Real number	Upper limit for plus/minus display and statistics in the reference unit or base unit
Mean tare weight	TARE g ?	Real number	Input for automatic tare subtraction
Machine number	MA-NO. ?	Integer number	Identification number for the filling machine
Counter	COUNTER ?	2...25 or 2...255*	Number of measurements for statistics *: if individual tare not used

### 7.2 The signallamp limits of the article

- \* Red range : weight value < TU
- Green range :  $TU \leq \text{weight value} \leq TO$
- Yellow range : weight value > TO

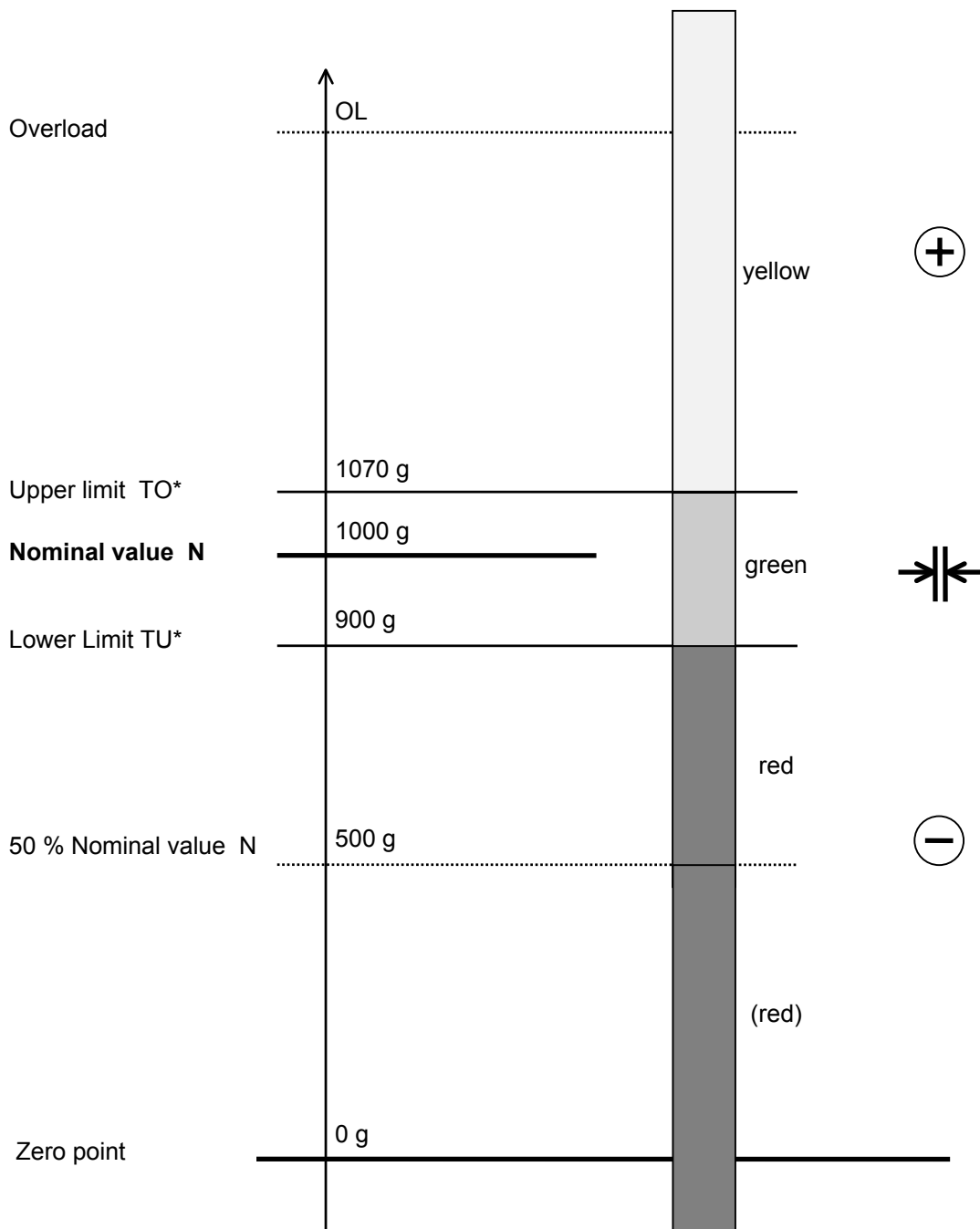

### 7.3 Storing an article

< STO >

< ART >

Enter article number

< ENTER >

Enter article variation

<ENTER>

Enter short code \*

< ENTER >

Enter product name \*

< ENTER >

Enter batch number \*

< ENTER >

Enter user name \*

< ENTER >

Enter reference density \*

< ENTER >

Enter nominal weight

< ENTER >

Enter first lower limit \*

< ENTER >

Limit will be automatically calculated simply on exiting.

Enter second lower limit \*

< ENTER >

Limit will be automatically calculated simply on exiting.

Enter lower limit \*

< ENTER >

Limit will be automatically calculated simply on exiting.

Enter upper limit \*

< ENTER >

Limit proportional to lower limit will be automatically calculated simply on exiting.

Enter mean tare \*

< ENTER >

Enter machine number \*

< ENTER >

Enter statistics counter \*

< ENTER >

\* Input only if activated in article variation.

## 7.4 Editing an article

An already stored article can be edited or changed:

< STO >

< ART >

Enter article number

< ENTER >

Enter article variation

<ENTER>

Enter short code \*

< ENTER >

Enter or confirm product name \*

< ENTER >

Enter or confirm batch number \*

< ENTER >

Enter or confirm user name \*

< ENTER >

Enter or confirm reference density \*

< ENTER >

Enter or confirm nominal weight

< ENTER >

Enter or confirm first lower limit \*

< ENTER >

Enter or confirm second lower limit \*

< ENTER >

Enter or confirm lower limit \*

< ENTER >

Enter or confirm upper limit \*

< ENTER >

Enter or confirm mean tare \*

< ENTER >

Enter machine number \*

< ENTER >

Enter statistics counter \*

< ENTER >

\* Input only if activated in article variation.

### 7.5 Loading an article from the memory

< RCL >  
< ART >  
Enter article number  
< ENTER >

### 7.6 Deleting an article from the article memory

< CLEAR >  
< ART >  
Enter article number  
< ENTER >

### 7.7 Deleting all articles from the memory

< CLEAR >  
< ART >  
'ALL'  
< ENTER >

### 7.8 Deleting the article from the working memory

< CLEAR >  
< ART >  
< ENTER >

This command also deletes from the working memory a reference value or a mean tare weight which is not entered with the article.

## 7.9 Barcodes and articles

Whenever an article number is entered, this may also be done using a barcode reader. Barcodes of types Code 39, EAN 8 and EAN 13 are accepted.

< STO >  
< ART >  
Read article number with barcode reader  
< ENTER >  
.....

The reading of a standard barcode, without prior input via the keyboard, will always be interpreted by the balance as < RCL > < ART > 'barcode' < ENTER >.

## 7.10 Table for automatic tolerance calculation (TU1, TU2)

Nominal value $Q_N$ in grams or millilitres	Allowable minus deviation ( $Q_N - TU1$ )	
	as % of $Q_N$	in grams or millilitres
5 to 50	9	-
50 to 100	-	4.5
100 to 200	4.5	-
200 to 300	-	9
300 to 500	3	-
500 to 1'000	-	15
1'000 to 10'000	1.5	-

$$TU2 = Q_N - 2 \times (Q_N - TU1)$$



#### 8.4 Deleting a tare from the tare memory

< CLEAR >  
< →T >  
Number of the tare memory  
< ENTER >

#### 8.5 Deleting all tares from the tare memory

< CLEAR >  
< →T >  
'ALL'  
< ENTER >

#### 8.6 Pre-setting tare using the decimal keypad

< →T >  
Enter mean tare weight  
< ENTER >

#### 8.7 Barcode and tare

The mean tare weight can be read directly with a barcode reader. The barcode must be of Type EAN 13. It must be specially coded and contain the tare. The reading of a specially coded barcode without prior input via the keypad will always be interpreted by the balance as < →T > 'barcode' < ENTER >.

## 9 Printout

All available measurements, tares and article data can be printed out using the < PRINT > key.

### 9.1 Printing out measurements

< PRINT >            The current measurement will be printed out

### 9.2 Allocating a fixed print format to the PRINT key

Three permanently programmed print formats may be allocated to the PRINT key:

Format 1:    current net-weight

Format 2:    date/time, article, current net-, gross- and tare-weight

Format 3:    date/time, article, current net-weight, article-definitions

< STO >

< PRINT >

Enter format number

< ENTER >

### 9.3 Printing out an article

< INFO >

< PRINT >

< ART >

Enter article number

< ENTER >

### 9.4 Printing out a list of articles

< INFO >

< PRINT >

< ART >

Enter 'ALL'

< ENTER >

### 9.5 Printing out a tare from the tare memory

< INFO >  
< PRINT >  
< →T >  
Enter tare number  
< ENTER >

### 9.6 Printing out the list of tares

< INFO >  
< PRINT >  
< →T >  
Enter 'ALL'  
< ENTER >

### 9.7 Printing out the current tare

< INFO >  
< PRINT >  
< →T >  
< ENTER >

### 9.8 Printing out the current density

< INFO >  
< PRINT >  
< DENS. >

### 9.9 Printing out the version of the Smartbox software

< INFO >  
< PRINT >  
< ↻ >

By skipping the <PRINT> key the information can be shown line by line in the display instead of being printed. Each line then will be shown for 2 seconds. By using the < ↻ > key the display can be halted or continued.

### 10 Finished pack checking with mean tare

Using the Smartbox you can weigh packed goods in accordance with the FPVO (Finished pack regulations) and the print out the predetermined data. You can check whether the weight of the goods is within pre-determined tolerances, for which a two-stage tolerance can be set. For this purpose, two lower tolerance limits can be entered.

#### 10.1 Finished pack checking with temporary article memory

If you have to determine just one series of measurements, you can use the temporary article memory or the working memory.

Before you enter the article, you must have defined and activated the statistics and the program run using the article variation.

In article variation 1, the run for FPVO with mean tare is pre-set, with the possible inputs for article number, product name, reference density, nominal value and tolerances automatically calculated in accordance with the table in Section 7.10, mean tare and statistics counter. The possible inputs may be extended (see also Chapter 3).

<i>Article preparation</i>	< ART >	
	Enter article number	
	< ENTER >	
	Enter product name	
	< ENTER >	
	Enter reference density for liquids	If no reference density is entered, remaining entries are in grams.
	< ENTER >	
	Enter nominal weight	
	< ENTER >	
	Enter mean tare	Optional input.
< ENTER >		
Enter statistics counter		
< ENTER >		

After input of the article, the statistics will start automatically and the series of measurements can be started.



### 11 Finished pack check with individual (prior) tare

With the Smartbox you can weigh packed goods in accordance with the FPVO (finished pack regulations), where you first take the empty pack for a series of measurements and subsequently the finished filled product in the next series of measurements. The Smartbox calculates the fill quantity of the individual goods and prints out the pre-determined data. You check whether the weight of the goods is within a pre-determined tolerance and for this it is possible to set a two-stage tolerance. For this purpose, two lower tolerance limits can be entered.

#### 11.1 Finished pack check using article memory

If you need to determine several series of measurements for the same product, then you work with the permanent article memory.

Before you store the article, you must have defined and activated the statistics and the program run by means of the article variation.

In the case of article variation 2, the run is pre-set for FPVO with individual (prior) tare, with the possible entry of article number, product name, reference density, nominal value, tolerances automatically calculated in accordance with the table in Section 7.10, mean tare and statistics counter.

The possible inputs may be extended (see also Chapter 3).

<i>Article</i>	< STO >	
<i>preparation</i>	< ART >	
	Enter article number	
	< ENTER >	
	Enter product name	
	< ENTER >	
	Enter reference density for liquids	If no reference density is entered, remaining entries are in grams.
	< ENTER >	
	Enter nominal weight	
	< ENTER >	
	Enter mean tare	Addition tare e.g. for bottle closure or labels (Optional input).
	< ENTER >	
	Enter statistics counter	
	< ENTER >	

After input of the article, the article must be loaded and the statistics started. It is then possible to start the series of measurements.



### 11.2 FPVO statistics printout with prior individual tare

Begin Date 11.11.2004 Time 07:47:24

Art.No. 7610235000015  
Prod. MINERAL WATER

#### 5 Measured Values

Tare	1	:	+	609.70	g
Tare	2	:	+	609.78	g
Tare	3	:	+	609.93	g
Tare	4	:	+	610.05	g
Tare	5	:	+	609.97	g

End Date 11.11.2004 Time 07:47:54

Begin Date 11.11.2004 Time 07:48:12

Art.No. 7610235000015  
Prod. MINERAL WATER

#### 4 Measured Values

Gross	1	:	+	1633.06	g
Gross	2	:	+	1633.14	g
Gross	3	:	+	1633.29	g
Gross	4	:		-----	
Gross	5	:	+	1633.41	g
	1	:	+	1021.39	ml
	2	:	+	1021.39	ml
	3	:	+	1021.39	ml
	5	:	+	1021.47	ml

Total	+	4085.63	ml
Mean	+	1021.41	ml
StdE.	+	0.04	ml
StdE. %		0.00	%
% Overfill	+	2.14	%
Max	+	1021.47	ml
Min	+	1021.39	ml

Density	+	0.9989	g/ml
Nom.Value	+	1000.00	ml
0 < TU1	+	985.00	ml 0.0 %
0 < TU2	+	970.00	ml 0.0 %
Tare	+	3.10	g

End Date 11.11.2004 Time 07:48:53

\*\* SAMPLE IS CONFORMAL \*\* (only if conformity-check is activated)

## 12 Finished pack check with individual (subsequent) tare

With the Smartbox you can weigh packed goods in accordance with the FPVO (finished pack regulations), where you first take the finished filled product for a series of measurements and subsequently the empty pack in the next series of measurements. The Smartbox calculates the fill quantity of the individual goods and prints out the pre-determined data. You check whether the weight of the goods is within a pre-determined tolerance and for this it is possible to set a two-stage tolerance. For this purpose, two lower tolerance limits can be entered.

### 12.1 Finished pack check using article memory

If you need to determine several series of measurements for the same product, then you work with the permanent article memory.

Before you store the article, you must have defined and activated the statistics and the program run by means of the article variation.

In the case of article variation 3, the run is pre-set for FPVO with individual (subsequent) tare, with the possible entry of article number, product name, reference density, nominal value and tolerances automatically calculated in accordance with the table in Section 7.10, mean tare and statistics counter. The possible inputs may be extended (see also Chapter 3).

<i>Article</i>	< STO >	
<i>preparation</i>	< ART >	
	Enter article number	
	< ENTER >	
	Enter product name	
	< ENTER >	
	Enter reference density for liquids	If no reference density is entered, remaining entries are
	< ENTER >	in grams.
	Enter nominal weight	
	< ENTER >	
	Enter mean tare	Addition tare e.g. for bottle closure
	< ENTER >	or labels (optional input).
	Enter statistics counter	
	< ENTER >	

After input of the article, the article must be loaded and the statistics started. It is then possible to start the series of measurements.



**12.2 FPVO statistics printout with subsequent individual tare**

Begin Date 11.11.2004 Time 07:36:26

5 Measured Values

Art.No. 7610800019138  
Prod. FULL-CREAM MILK

5 Measured Values

Gross 1 : + 1059.76 g  
Gross 2 : + 1059.90 g  
Gross 3 : + 1059.89 g  
Gross 4 : + 1059.97 g  
Gross 5 : + 1060.03 g

End Date 11.11.2004 Time 07:36:57

Begin Date 11.11.2004 Time 07:37:10

Art.No. 7610800019138  
Prod. FULL-CREAM MILK

4 Measured Values

Tare 1 : + 37.45 g  
Tare 2 : -----  
Tare 3 : + 37.58 g  
Tare 4 : + 37.56 g  
Tare 5 : + 37.77 g1 : + 1000.01 ml  
3 : + 1000.01 ml  
4 : + 1000.11 ml  
5 : + 999.96 mlTotal + 4000.09 ml  
Mean + 1000.02 ml  
StdE. + 0.06 ml  
StdE. % + 0.01 %  
% Overfill 0.00 %  
Max + 1000.11 ml  
Min + 999.96 mlDensity + 1.0223 g/ml  
Nom.Value + 1000.00 ml  
0 < TU1 + 984.70 ml 0.0 %  
0 < TU2 + 969.40 ml 0.0 %

End Date 11.11.2004 Time 07:37:46

\*\* SAMPLE IS CONFORMAL \*\* (only if conformity-check is activated)

## 13 Mean tare determination

The mean tare can be determined using the Smartbox.

### 13.1 Mean tare determination with temporary article memory

If you have to determine just one series of measurements, you can use the temporary article memory or the working memory.

Before you enter the article, you must have defined and activated the statistics and the program run using the article variation.

In article variation 4, the run for mean tare determination is pre-set, with the possible inputs for article number, product name, nominal value and statistics counter.

The possible inputs may be extended (see also Chapter 3).

<i>Article</i>	< ART >
<i>preparation</i>	Enter article number
	< ENTER >
	Enter product name
	< ENTER >
	Enter nominal weight
	< ENTER >
	Enter statistics counter
	< ENTER >

After input of the article, the statistics will start automatically and the series of measurements can be started.



### 14 Daily and weekly statistics (STAT 1 and STAT 2)

For each article smartbox automatically generates daily and weekly statistics. By using the STAT keys a statistics report can be printed.

Although STAT 1 and STAT 2 work exactly the same way, STAT 1 is usually used for the daily and STAT 2 for the weekly statistics.

Both of them can be started and finished at any time. The statistics of an article can be finished by printing the statistics report of the concerned article and then clearing this statistics.

#### 14.1 Daily statistics printout (STAT 1)

*Start* < STAT 1 >  
*printout* < ART >  
Enter short code or article number or 'ALL'  
< ENTER >

1. Statistic  
Begin Date 21.03.2004 Time 08:55:03

Art.No. 7610235000015  
Prod. MINERAL WATER

3 Series of Measurements  
15 Measured Values

Total + 15186.61 ml  
Mean + 1012.44 ml  
StdE. + 22.81 ml  
StdE. % + 2.25 %  
% Overfill + 1.24 %  
Max + 1022.86 ml  
Min + 870.32 ml

Density + 1.0000 g/ml  
Nom.Value + 1000.00 ml  
1 < TU1 + 985.00 ml 6.7 %  
1 < TU2 + 970.00 ml 6.7 %

End Date 21.03.2004 Time 16:14:09

Clear Statistic Y/N < Y > or < N > (only STAT 1 of this article will be cleared)

### 14.2 Weekly statistics printout (STAT 2)

*Start* < STAT 2 >  
*printout* < ART >  
Enter short code or article number or 'ALL'  
< ENTER >

2. Statistic  
Begin Date 20.03.2004 Time 08:45:05

Art.No. 7610235000015  
Prod. MINERAL WATER

6 Series of Measurements  
30 Measured Values

Total	+ 30570.56 ml		
Mean	+ 1019.02 ml		
StdE.	+ 21.49 ml		
StdE. %	+ 2.11 %		
% Overfill	+ 1.90 %		
Max	+ 1106.63 ml		
Min	+ 870.32 ml		
Density	+ 1.0000 g/ml		
Nom.Value	+ 1000.00 ml		
2 < TU1	+ 985.00 ml	6.7 %	
1 < TU2	+ 970.00 ml	3.3 %	

End Date 24.03.2004 Time 16:22:40

Clear Statistic Y/N < Y > or < N > (only STAT 2 of this article will be cleared)

### 14.3 Deleting statistics

< CLEAR >  
< STAT1 > or < STAT2 >  
Enter article number or 'ALL'  
< ENTER >

## 15 Defining print formats

The user has the possibility to create his own print formats. For this purpose there are 15 freely definable text lines and over 70 pre-defined text lines (measurements, results) available. These text lines can be combined in a print format and this print format can then be assigned to the PRINT key. Furthermore, to all print formats (pre-defined and free-defined) a certain number of linefeeds can be appended.

### 15.1 Storing an ASCII text line

```
< STO >  
< SHIFT >  
' S '  
Enter text number  
< ENTER >  
Enter text  
< ENTER >
```

There are 15 memory locations available for ASCII and HEX lines. Text numbers from 01 to 15 are possible. Text number 01 will also always be used for the barcode labels. 40 characters can be entered for each memory location.

### 15.2 Storing a line of HEX (control codes)

```
< STO >  
< SHIFT >  
' H '  
Enter HEX line number  
< ENTER >  
Enter HEX Code           always 2-digit codes: Exp. 1B 30 2B 41 42 (= ESC 0 + A B)  
< ENTER >
```

There are 15 memory locations available for ASCII and HEX lines. Text numbers from 01 to 15 are possible. Text number 01 will also always be used for the barcode labels. 80 characters, i.e. 40 ASCII symbols, can be entered for each memory location.

### 15.3 Deleting a text or HEX line

```
< STO >  
< SHIFT >  
' H '  
Enter HEX line number  
< ENTER >  
Enter '00' ( HEX symbol 0)  
< ENTER >
```

### 15.4 Pre-defined text lines

The following is a list of the fixed texts with results and measurements.

**Standard bold : text**    *Italics* : result or measurement    **CR LF** : Carriage Return, Linefeed

16    **CR LF**  
17    **Date**    *Date*                    **Time**    *Time*    **CR LF**

18    **Art.No.**    *Article number* **CR LF**  
19    *Article number* **CR LF**  
20    **S.Code**    *Short code* **CR LF**  
21    *Short code* **CR LF**  
22    **Prod.**      *Product name* **CR LF**  
23    *Product name* **CR LF**  
24    **Lot-No.**    *Lot number* **CR LF**  
25    *Lot number* **CR LF**  
26    **Operator**    *Operator* **CR LF**  
27    *Operator* **CR LF**  
28    **Net**         *Current weight* **CR LF**  
29    *Current weight* **CR LF**  
30    **Net 1**        *Weight in unit 1* **CR LF**  
31    *Weight in unit 1* **CR LF**  
32    **Gross**        *Gross weight* **CR LF**  
33    *Gross weight* **CR LF**  
34    **Density**      *Reference density* **CR LF**  
35    *Reference density* **CR LF**  
36    **Nom.Value**    *Nominal value* **CR LF**  
37    *Nominal value* **CR LF**  
38    **TU1**         *First lower tolerance limit* **CR LF**  
39    *First lower tolerance limit* **CR LF**  
40    **TU2**         *Second lower tolerance limit* **CR LF**  
41    *Second lower tolerance limit* **CR LF**  
42    **TU**            *Lower tolerance limit* **CR LF**  
43    *Lower tolerance limit* **CR LF**  
44    **TO**            *Upper tolerance limit* **CR LF**  
45    *Upper tolerance limit* **CR LF**  
46    **Tare Art.**    *Article Tare* **CR LF**  
47    *Article Tare* **CR LF**  
48    **Tare**         *Current Tare* **CR LF**  
49    *Current Tare* **CR LF**

50    *Input text* **CR LF**

51    *Tare barcode ENA13*  
52    *Density barcode ENA13*  
53    *Article number barcode ENA8*  
54    *Article number barcode ENA13*  
55    *Article number barcode Code39*  
56    *Current weight gramme barcode EAN13*  
57    *Current weight ml barcode EAN13*

58 **Begin Date** *Date* **Time** *Time* **CR LF**  
 59 **End Date** *Date* **Time** *Time* **CR LF**

Measurements and results of the current statistics

60 *Number of measurements* **Measurements CR LF**  
 61 **Tare or Gross** *Number : Current statistics weight CR LF*  
 62 *Number : Current statistics net value CR LF*  
 63 **Total** *Total of the statistics net value CR LF*  
 64 **Mean** *Statistical mean net value CR LF*  
 65 **StdE.** *Standard deviation of the statistics net value CR LF*  
 66 **StdE.%** *Relative standard deviation of the stat. net value CR LF*  
 67 **% Overfill** *Percentage overfill of the stat. net value CR LF*  
 68 **Max** *Maximum of the statistics net value CR LF*  
 69 **Min** *Minimum of the statistics net value CR LF*  
 70 *Number less than TU1* < **TU1** *1<sup>st</sup> lower tolerance limit Percentage CR LF*  
 71 *Number less than TU2* < **TU2** *2<sup>nd</sup> lower tolerance limit Percentage CR LF*  
 72 *Number less than TU* < **TU** *Lower tolerance limit Percentage CR LF*  
 73 *Number more than TO* > **TO** *Upper tolerance limit Percentage CR LF*

Measurements and results of the daily and weekly statistics

74 *Number of measurements* **Measurements CR LF**  
 75 *Number of series of measurements* **Series of measurements CR LF**  
 76 **Total** *Total of all statistics net value CR LF*  
 77 **Mean** *Average of all statistics net value CR LF*  
 78 **StdE.** *Standard deviation of all statistics net value CR LF*  
 79 **StdE.%** *Relative standard deviation of all stat. net value CR LF*  
 80 **% Overfill** *Percentage overfill of all stat. net value CR LF*  
 81 **Max** *Maximum of all statistics net value CR LF*  
 82 **Min** *Minimum of all statistics net value CR LF*  
 83 *Number less than TU1* < **TU1** *1<sup>st</sup> lower tolerance limit Percentage CR LF*  
 84 *Number less than TU2* < **TU2** *2<sup>nd</sup> lower tolerance limit Percentage CR LF*  
 85 *Number less than TU* < **TU** *Lower tolerance limit Percentage CR LF*  
 86 *Number more than TO* > **TO** *Upper tolerance limit Percentage CR LF*

Miscellaneous

87 **\*\* SAMPLE IS CONFORMAL \*\*** *resp. -- SAMPLE IS NOT CONFORMAL -- CR LF (see chap. 3.5)*  
 90 *Date*  
 91 *Time*  
 92 *Smartbox Application CR LF*  
 93 *Smartbox Software version CR LF*  
 94 *Balance Model CR LF*  
 95 *Balance Software version CR LF*  
 96 *Balance Serial number CR LF*

### 15.5 Storing a print format

```
< STO >  
< SHIFT >  
' P '  
Enter print format number  
< ENTER >  
Enter output function and text numbers  
< ENTER >
```

Print format numbers can be 1,2 and 4 to 15. Print format 1 is prefixed to all permanently programmed print formats as a header, print format 2 is appended as terminator.

Example : *Print format 1*  
*Statistics printout*  
*Print format 2*

1 to 5 may be entered as the output function (one digit), see also Section 3.2.  
The text numbers are always two position. A maximum of 40 text numbers can be entered.

```
Example : <STO>  
<SHIFT>  
'P'  
'4'          Printformat 4  
<ENTER>  
'1172816'    1 . . . . . : Output-Function = 1 = Report printer (see also Section 3.2.)  
              . 17. . . . : Date/Time  
              . . . 28. . : Current weight  
              . . . . . 16 : Additional. CR,LFs  
  
<ENTER>
```

### 15.6 Allocate print format to the PRINT key

Print formats with the numbers 1 to 21 can be allocated to the Print key.

```
< STO >  
< PRINT >  
Enter format  
< ENTER >
```

Format 1	current net-weight
Format 2	date/time, article, current net-, gross- and tare-weight
Format 3	date/time, article, current net-weight, article-definitions

Format 4 - 15      Freely definable print formats

Format 16 - 21    Barcode label print format    (Barcode print formats are described in Chapter 16)

## **16 Eltron LP2022SE or LP2824 Barcode-Printer**

Labels with the article number, the tare and the reference weight, which can be read directly into the balance with a barcode-reader, can be printed out with the “Eltron LP2022SE” or “LP2824” barcode-printer. (Note: LP2824 must be configured to LINE-MODE.)

### **16.1 Print article number in EAN8 code (Printformat 16)**

Allocate **printformat 16** to the Print key, as described in Chapter 15.6.  
Load an article number into the working memory and press the < PRINT > key.  
A label with the article number in EAN8 Code will be printed out.

### **16.2 Print article number in EAN13 code (Printformat 17)**

Allocate **printformat 17** to the Print key, as described in Chapter 15.6.  
Load an article number into the working memory and press the < PRINT > key.  
A label with the article number in EAN13 Code will be printed out.

### **16.3 Print article number in Code39 (Printformat 18)**

Allocate **printformat 18** to the Print key, as described in Chapter 15.6.  
Load an article number into the working memory and press the < PRINT > key.  
A label with the article number in Code 39 will be printed out.

### **16.4 Print tare weight in EAN13 code (Printformat 19)**

Allocate **printformat 19** to the Print key, as described in Chapter 15.6.  
Place a container on the balance pan and press the < PRINT > key.  
A label with the tare weight in EAN13 Code will be printed out.

### **16.5 Print reference density in EAN13 code (Printformat 20)**

Allocate **printformat 20** to the Print key, as described in Chapter 15.6.  
Enter the reference density and press the < PRINT > key.  
A label with the reference density in EAN13 Code will be printed out.

### **16.6 Print text-label (Printformat 21)**

Allocate **printformat 21** to the Print key, as described in Chapter 15.6 and press the < PRINT > key.  
A label with data on the current article and measurement will be printed out.

## 17 Barcode-Reader

A barcode-reader can be attached to any Smartbox.

### 17.1 Storing an article number with the barcode-reader

< STO >  
< ART >  
Read in barcode  
< ENTER >  
.....  
Enter remaining information on the article

### 17.2 Loading an article with the barcode-reader

Read in barcode with the reader. If the corresponding article is stored, it will automatically be loaded into the working memory and the balance operates as with an < RCL > < ART >...  
If the corresponding article is not found, the barcode read in remains in working memory as an identification number.

### 17.3 Reading in a reference density with the barcode-reader

Only specially coded barcodes can be read in as a reference density. This code contains an identification and the reference density in g/ml. This label can be produced as described in Chapter 16.5.

### 17.4 Reading in tare weight with the barcode-reader

Only specially coded barcodes can be read in as a tare weight. This code contains an identification and the tare weight in grams. This label can be produced as described in Chapter 16.4.  
If the barcode is read in, the tare of the balance will be set.

## 18 Reference-Balance

A balance with RS232-interface may be used as a reference-balance.

If more than one reference-balance is allocated to the input channels, an input channel (1....) must be supplied after the < BASE > Key.

### 18.1 Configuring the reference-balance

The interface parameters of the main- and reference-balances must be the same.  
The base unit of the reference-balance must be in grams.

### 18.2 Transferring tare weight

< STO >  
< → T >  
Enter tare number  
< ENTER >  
< BASE >  
Enter base number  
< ENTER >

### 19 Interfaces and accessories

#### 19.1 Standard interface

One or two peripherals may be attached to the standard interfaces RS232 (Ch.1, Ch.2) of the Smartbox.

Interface cable RS232 for a peripheral (bi-directional)  
for Series 320, 490  
Order No. 350-xxxx



Barcode-Reader  
for Series 320, 490  
Order-No. 350-xxxx

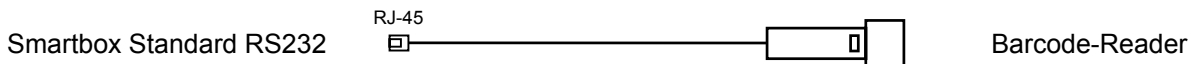

## 20 Controlling the Smartbox remotely via the interface

Remote control of the Smartbox functions is effected in a similar manner to input via the keypad. Each function has a key code, otherwise the ASCII Code is used. A Smartbox remote control command always starts with '#\$'.

### 20.1 Key code for the functions

\A	< DISP >	
\B	< STAT1 >	
\C	< STAT2 >	
\D	< DENS >	
\E	< MEM >	
\F	< MENU >	
\G	< CONF >	
\H	< ART >	
\I	< TARE >	
\J	< STO >	
\K	< ↻ >	
\L	< RCL >	
\M	< BASE >	
\N	< INFO >	
\O	< PRINT >	
\P	< CLR >	
\Q	< SHIFT >	( not used )
\R	< ENTER >	

### 20.2 Direct commands

Data in the direct commands are separated with a Tab (Hex 09) or semicolon (;). In setting or storing an article all components of the article must always be transferred, even if not used. The numerical values may only be transferred in grams, millilitres or percentages. No other weight units will be accepted. 0 g must be employed for unused numerical values. A hyphen may be used as a filler for alphanumeric values which are not used.

#### 20.2.1 Direct commands for the article

Place article in working memory      #SETA...

```
#SETA 444;4;TEST 444;146-GHK;Roland Moor;0;g;300;g;291;g;282;g;250;g;350;g;25;g;343434;5;1
```

Store article in memory                #STOA...

Articles with the same article number will be overwritten.  
If all article memory is full, subsequent articles will be ignored.

```
#STOA 111;1;TEST 111;123-ABC;Roland Moor;0.9899;g/ml;300;ml;291;ml;282;ml;291;ml;309;ml;25;g;123456;5;1
```

```
#STOA 222;2;TEST 222;146-GHK;Roland Moor;0;g;300;g;291;g;282;g;250;g;350;g;25;g;365656;5;1
```

```
#STOA 333;3;TEST 333;123-ABC;Roland Moor;0.899;g/ml;600;ml;590;ml;580;ml;580;ml;620;ml;25;g;7878;5;1
```

```
#STOA 444;4;TEST 444;146-GHK;Roland Moor;0;g;300;g;291;g;282;g;250;g;350;g;25;g;343434;5;1
```

Read an article                        #GETA 111

Read all articles                      #GETA ALL

The articles will be printed out in the same format, as stored with #STOA...  
The data received can be stored in a text file and further processed using Excel.

Clear an article                        #CLRA 111

Clear all articles                      #CLRA ALL

### 20.2.2 Direct commands for the tare

Set tare in working memory                   #SETT...

#SETT 25.25;g

Store tare in memory                        #STOT...

#STOT 1;25.25;g

#STOT 13;452.42;g

#STOT 53;100;g

#STOT 244;200.42;g

Read a tare                                    #GETT 13

Read all tares                                #GETT ALL

The tare weights are printed out in the same format as they are stored with #STOT..  
The data received can be stored in a text file and further processed using Excel.

Clear a tare                                   #CLRT 13

Clear all tares                               #CLRT ALL

### 20.2.3 Direct commands for the strings and print formats

Set print format #SETP...  
(corresponds to < STO > < PRINT > ....)

#SETP 3

Store string in memory #STOS...

#STOS 1;PRECISA Gravimetrics AG

#STOS 13;Moosmattstrasse 32

Store hex string in memory #STOH...

#STOH 3;0D0A0D0A303132204444142

#STOH 4;E0E4E2E60D0A0D0A

Store print format in memory #STOP...

The first position of the string is occupied by the output function, after which is the text number, always two positions (see also Section 15.5).

#STOP 1;1011613160316

#STOP 5;101161316

Read a string #GETS 13

Read all strings #GETS ALL

Read a print format #GETP 13

Read all print formats #GETP ALL

The strings and print formats will be printed out in the same format as stored with #STO...  
The data received can be stored in a text file and further processed using Excel.

Delete a string #CLRS 13

Delete all print formats #CLRP ALL

## 21 Tips and tricks

### 21.1 < DISP > key

If an article is in working memory, it is possible to switch the lower display between capacity-indicator and text-display.

### 21.2 < ↻ > key

During the info display it is possible to stop or re-display individual lines with the < ↻ > key.

### 21.3 < - > key

If the working memory contains a nominal value, the weight display can be switched between net weight and weight difference from nominal using the < - > key.  
If the difference-display is active, a circle will appear in the display.